



OPENERS & CLOSERS®
Secure locking solutions

O&C

CATALOGUE 2018

ELECTRIC STRIKES · ELECTROMAGNETIC LOCKS
ELECTRIC LOCKS · ACCESSORIES

openers-closers.com

OPENERS AND CLOSERS S.L.

Calle Agricultura 17 (Nave 12), 08980 Sant Feliu de Llobregat, Barcelona

openers-closers.com | Phone 0034 93 408 05 15 | sales@openers-closers.com

ABOUT US OPENERS&CLOSERS

OUR STORY	
Who we are	4 - 5
MISSION & VALUES	
What do we do	
What makes us different	
Why us	6-7
VISION	
Where we are going	7
CONSULTANCY	
Looking for the best solution for your project	8-9
NORMS	
According to standards	
EN 14846:2008	10
EN 1155:1997	11
EN 50131-2-6:2008	11
EN 179:2008	12
EN 1125:2008	13

ELECTRIC AND ELECTRONIC STRIKES

15

CODING	16 - 17	SERIES 2	
		The original	24
OUR MODELS	18 - 19	Series 2S	26 - 27
FUNCTIONS		SERIES 3	
Glossary	20 - 21	The Evolution!	30
		Series 3 and 3D	32 - 33
INSTALLATION OF AN ELECTRIC STRIKE	22 - 23	SERIES 4	
		Reinforced!	36
		Series 4, 4B and 4F	38 - 39
		Series 4A	40 - 41
		SERIES 5	
		Revolution!	46
		Series 5, 5U and 5E	48 - 49
		Series 5F, 5UF and 5EF	50 - 51
		SERIES 7	
		Waterproof!	56
		SERIES 9	
		Armoured	60
		SERIES 25	
		Small and incredible	64
		Series 25 and 25E	66 - 67
		FACEPLATES	70
		Box	74
		Short	75
		Angled	76 - 77
		Long	78 - 79
		COMPLEMENTS	
		Dummy and Black box	80 - 81

ELECTROMAGNETIC LOCKS

INSTALLATION OF AN ELECTROMAGNETIC LOCK	84 - 85
SERIES ME	
Slim and strong	86
SERIES MEX	
Maximum resistance	90
SERIES DH	
Door Holder	94 - 95
SERIES SH	
Shearlock	96 - 97

ELECTRIC LOCKS

99

SERIES PGX	
Micro bolt	100 - 101
SERIES CE	
Intelligent	102 - 103
SERIES OC	
Basic	104 - 105
SERIES BO	
Versatile	104 - 105
SERIES EVA	
Dual functionality	106 - 107

DOOR ACCESSORIES

109

SERIES PB	
Detection systems and fire alarm	110 - 111
SERIES TL	
Traffic lights	112 - 113
SERIES PS	
Power Supplies	114
Transformers	115
SERIES DDC	
Electric contacts	116 - 117
SERIES FX	
Door loops	118 - 119
SERIES CM	
Magnetic contacts	120 - 121
SERIES AC	
Activating doors remotely	122 - 123



OUR STORY

WHO WE ARE

FAMILY & INTERNATIONAL SPIRIT

OPENERS AND CLOSERS is a family company based in Barcelona since 1989. The company was founded with the objective of producing high quality electric strikes for the international market. Nowadays, his daughter and sons run the company with the same spirit and passion while looking forward to new goals and achievements.

We built our first electric strike in a small garage, and in 1990 we started our worldwide adventure by making our first sale in the UK. Over the next 10 years, we expanded our market all over the EU, always offering new and innovative products to satisfy all of our clients' needs.

New challenges followed the turn of the century when we decided to sell our products at a national level. Time had come to build up our brand; our aim: excellence.

Even during the financial crisis of 2008 and our internal restructuring in 2012, we continued developing new products and ideas.

The positive changes done over the last few years have helped us grow. Now we are ready to take the leap with our new products, and the experience acquired to develop them.

WHAT WE BELIEVE

PEOPLE, TALENT & DIVERSITY

Solving the hardest problems requires the best team.

People are our most important asset and key to develop fresh, new ideas, which are the basis for our future. That is why we invest in developing our team's skills; creating an environment that furthers their growth as leaders.

In order to succeed we need open-minded people, willing to try original concepts, to take risks and challenge their own limits. We actively encourage team members from different cultures, perspectives and life experiences to embrace the opinions of their peers and be receptive to brainstorming.

WHY WE ARE HERE

LOVE & PASSION

We believe in building superior door locks that keep opening and closing doors.

Our core business is to conceive, design, manufacture, and test high-quality electric strikes and electromagnetic locks for door manufacturers and access control companies.





MISSION & VALUES

WHAT DO WE DO

THINK, DESIGN & CRAFT

We secure doors for your comfort and safety. Our target is to make our brand known as a leading company in design and development of secure locking solutions for doors and access control systems all over the world.

We believe less is more. That is why we simplify the range of products available on the market. By establishing worldwide standards, we have increased our efficiency and environmental friendliness.

For nearly three decades, we have advised companies about proper locking systems. We specialize in mechanical, electromechanical, electromagnetic and electronic solutions for doors. Cutting-edge products with high quality standards for the public and private sector at a reasonable price.

Our motto: you press the button; we do the rest.

WHAT MAKES US DIFFERENT

INNOVATION, QUALITY & SERVICE

We think out of the box. Creating breakthrough products and services to thrill our customers, who are the inspiration behind our constant betterment.

We pioneered in the inclusion of an electronic circuit in our electric strikes and maglocks which enables them to work 100% on AC/DC.

Recently we opened a new factory equipped with the latest technology. This new site will allow us to operate in completely new ways, focusing on innovation and process optimization while staying environmentally friendly.

The continuous improvement process of our product and infrastructure drives us to do better and one of the key aspects is to keep differentiating our products building them with precision and care.

We are proud of what we have become. O&C has evolved and strengthened from its humble beginnings but we know there is still much work ahead of us.

WHY US?

BRAVE & TOUGH

We are small, but we do big things. Always improving our products and services, constantly seeking the best results.

We are obsessed with details because that is the way to obtain simplicity while retaining knowledge; use the latest technologies while remaining sustainable; and always find the best solutions for our clients.

Corporate values

Innovation
Quality
Service

Personal values

Discipline
Self-criticism
Proactivity
Perseverance
Receptiveness towards change
Responsibility
Learning capacity

VISION

WHERE WE ARE GOING

SUSTAINABLE GROWTH & IOT

We are a growth company. Our commitment is to keep expanding our brand into new international markets and fulfill our efficiencies of lean manufacturing while minimizing our environmental impact.

The initiative of O&C is to pursue sustainable development and excellence for all its actions, paying particular attention to people, their working conditions and the quality of production processes.

The Internet of Things (IoT) creates new opportunities to integrate computer-based systems into our products and therefore introduce intelligent and smart locks that make our life easier and safer.

CONSULTANCY

Looking for the best solution for your project



WHAT WE CAN DO

ADVISE & DEVELOPMENT

We offer product development consultancy helping our clients get stuff done.

Consultancy on your existing project about norms, products or solutions available.

Customize our existing product to match new specifications.

Develop your project based on our insight.

Create unique designs with a multidisciplinary team of product engineers working especially for you.

NORMS

EN 14846:2008 Electromechanically operated locks and striking plates.

Digit	1	2	3	4	5	6	7	8	9
Description	Category of use	Durability and load on latchbolt	Door mass and closing force	Suitability for use on fire/smoke doors	Safety	Corrosion, temperature and humidity	Security	Security – Electrical function	Security – Electrical manipulation
Grade	3	Y	3	E	0	L	0	1	0

Digit	Description	Grade of the product
1	Category of use	Grade 1: Low frequency of use by people with a high incentive to exercise care and a small chance of misuse, e.g. internal residential doors Grade 2: Medium frequency of use by people with some incentive to exercise care but where there is some chance of misuse, e.g. internal office doors Grade 3: High frequency of use by public or others with little incentive to exercise care and with a high chance of misuse, e.g. doors in public buildings
2	Durability and load on latchbolt	Grade A: 50.000 test cycles without side-load Grade B: 100.000 test cycles without side-load Grade C: 200.000 test cycles without side-load Grade F: 50.000 test cycles with 10N side-load Grade G: 100.000 test cycles with 10N side-load Grade H: 200.000 test cycles with 10N side-load Grade L: 100.000 test cycles with 25N side-load Grade M: 200.000 test cycles with 25N side-load Grade R: 100.000 test cycles with 50N side-load Grade S: 200.000 test cycles with 50N side-load Grade W: 100.000 test cycles with 120N side-load Grade X: 200.000 test cycles with 120N side-load Grade Y: 200.000 test cycles with 250N side-load
3	Door mass and closing force	Grade 1: Up to 100 kg and closing force max. 50N Grade 2: Up to 200 kg and closing force max. 50N Grade 3: Over de 200 kg and closing force max. 50N Grade 4: Up to 100 kg and closing force max. 25N Grade 5: Up to 200 kg and closing force max. 25N Grade 6: Over de 200 and closing force max. 25N Grade 7: Up to 100 kg and closing force max. 15N Grade 8: Up to 200 kg and closing force max. 15N Grade 9: Over de 200 kg and closing force max. 15N
4	Suitability for use on fire/smoke doors	Grade 0: No requirement (not intended for use on fire/smoke doors) Grade A: Suitable for use on smoke door assemblies only Grade B: Suitable for use on smoke/fire door assemblies (≤15 minutes) Grade C: Suitable for use on smoke/fire door assemblies (≤30 minutes) Grade D: Suitable for use on smoke/fire door assemblies (≤60 minutes) Grade E: Suitable for use on smoke/fire door assemblies (≤90 minutes) Grade F: Suitable for use on smoke/fire door assemblies (≥120 minutes)
5	Safety	Grade 0: No requirement, but note: an electromechanically operated lock or striking plate conforming to this standard can, at the same time, also be part of an exit device conforming to EN 179 or EN 1125, or part of an exit system conforming to prEN 13633 or prEN 13637
6	Corrosion, temperature and humidity	Grade 0: No defined, no defined, no defined Grade A: No defined, no defined, humidity resistance level 1 Grade B: No defined, no defined, humidity resistance level 2 Grade C: Mild corrosion resistance (24h), +5°C up to +55°C, humidity resistance level 1 Grade D: Moderate corrosion resistance (48h), +5°C up to +55°C, humidity resistance level 1 Grade E: High corrosion resistance (96h), +5°C up to +55°C, humidity resistance level 1 Grade F: Very high corrosion resistance (240h), +5°C up to +55°C, humidity resistance level 1 Grade G: Moderate corrosion resistance (48h), -10°C up to +55°C, humidity resistance level 1 Grade H: High corrosion resistance (96h), -10°C up to +55°C, humidity resistance level 1 Grade J: Very high corrosion resistance (240h), -10°C up to +55°C, humidity resistance level 1 Grade K: Moderate corrosion resistance(48h), -25°C up to +70°C, humidity resistance level 2 Grade L: High corrosion resistance (96h), -25°C up to +70°C, humidity resistance level 2 Grade M: Very high corrosion resistance (240h), -25°C up to +70°C, humidity resistance level 2 Grade N: No defined, -25°C up to +70°C, humidity resistance level 1 Grade P: No defined, -25°C up to +70°C, humidity resistance level 2
7	Security	Grade 0: Applies for locks without any protective effect Grade 1: Minimum protective effect without drilling resistance Grade 2: Low protective effect without drilling resistance Grade 3: Medium protective effect without drilling resistance Grade 4: High protective effect without drilling resistance Grade 5: High protective effect with drilling resistance Grade 6: Very high protective effect without drilling resistance Grade 7: Very high protective effect with drilling resistance
8	Security – Electrical function	Grade 0: No status indicator Grade 1: Audio or visual signal from lock to indicate that deadbolt is fully thrown and deadlocked
9	Security – Electrical manipulation	Grade 0: No requirements Grade 1: Resistance to electrostatic discharge EN 61000-4-2 level 2 Grade 2: Voltage drop protection, protection against cutting of cables, resistance to electromagnetic manipulation, resistance to electrostatic discharge EN 61000-4-2 level 4 and resistance to electrostatic manipulation EN 61000-4-2 level 4 Grade 3: Voltage drop protection, protection against cutting of cables, protection against wire manipulation, resistance to electromagnetic manipulation, resistance to electrostatic discharge EN 61000-4-2 level 4 and resistance to electrostatic manipulation EN 61000-4-2 level 4

EN 1155:1997 Electrically powered hold-open devices for swing doors.

Digit	1	2	3	4	5	6
Description	Category of use	Durability	Hold-open power size	Suitability for use on fire/smoke doors	Safety	Corrosion resistance
Grade	3	5	3/4	1	1	3

Digit	Description	Grade of the product
1	Category of use	Grade 3: High frequency use by public and others with little incentive to exercise care.
2	Durability	Grade 5: 50.000 cycles. For all electrically powered hold-open devices Grade 8: 500.000 cycles. For all electrically powered hold open devices and free swing door closers and devices that contain operating arms.
3	Hold-open power size	Power 3: Recommended door leaf width Max 950mm Test door mass 60 kg Overload test drop weight 15kg Test door friction Max 0,3 N m Power 4: Recommended door leaf width Max 1100mm Test door mass 80 kg Overload test drop weight 18kg Test door friction Max 0,4 N m Power 5: Recommended door leaf width Max 1250mm Test door mass 100 kg Overload test drop weight 21kg Test door friction Max 0,5 N m Power 6: Recommended door leaf width Max 1400mm Test door mass 120 kg Overload test drop weight 27kg Test door friction Max 0,6 N m Power 7: Recommended door leaf width Max 1600mm Test door mass 160 kg Overload test drop weight 36kg Test door friction Max 0,8 N m
4	Suitability for use on fire/smoke doors	Grade 1: Suitable for use on fire/smoke door assemblies, subject to satisfactory assessment of the contribution of the electrically powered hold-open device to the resistance of specified fire/smoke door assemblies.
5	Safety	Grade 1: All electrically powered hold-open devices are required to satisfy the essential requirement of safety in use. Therefore only grade 1 is identified.
6	Corrosion resistance	Grade 0: No defined corrosion resistance Grade 1: Mild resistance Grade 2: Moderate resistance Grade 3: High resistance Grade 4: Very high resistance

EN 50131-2-6:2008 Intrusion and hold-up systems. Part 2-6: Opening contacts (magnetic).

Digit	1	2
Description	Enviromental class	Security grade
Grade	4	3

Digit	Description	Grade of the product
1	Enviromental class	Class 1: Civil interior Class 2: Industrial interior Class 3: Exterior but covered Class 4: Unprotected exterior
2	Security grade	Grade 1: Low risk, attacks from inexperienced subjects Grade 2: Medium-low risk, attacks from subjects with minimal skills Grade 3: Medium-high risk, attacks from subjects with high skills Grade 4: High risk, attacks from subjects who have specific knowledge of the system

EN 179:2008 Emergency exit devices operated by a lever handle or push pad, for use on escape routes.

Digit	1	2	3	4	5	6	7	8	9	10
Description	Category of use	Durability	Door mass	Suitability for use on fire/smoke doors	Safety	Corrosion resistance	Security	Projection of operating element	Type of operation	Field of door application
Grade	3	6	5	0	1	3	2	1	A	B

Digit	Description	Grade of the product
1	Category of use	Grade 3: High frequency use by public and others with little incentive to exercise care
2	Durability	Grade 6: 100.000 test cycles Grade 7: 200.000 test cycles
3	Door mass	Grade 5: Up to 100 kg Grade 6: Up to 200 kg Grade 7: Over 200 kg
4	Suitability for use on fire/smoke doors	Grade 0: Not approved for use on fire/smoke door assemblies Grade A: Suitable for use on smoke door assemblies, subject to satisfactory assessment of the contribution of the panic/emergency device to the smoke resistance of specified smoke door assemblies (see EN 1634-3) Grade B: Suitable for use on fire/smoke door assemblies, subject to satisfactory assessment of the contribution of the panic/emergency device to the fire resistance of specified fire/smoke door assemblies (see EN 1634-1)
5	Safety	Grade 1: All exit devices are required to satisfy the essential requirement of safety in use.
6	Corrosion resistance	Grade 3: High resistance (96 salt spray hours) Grade 4: Very high resistance (240 salt spray hours)
7	Security	Grade 2: 1000 N Grade 3: 2000 N Grade 4: 3000 N Grade 5: 5000 N
8	Projection of operating element	Grade 1: Projection up to 150 mm (large projection) Grade 2: Projection up to 100 mm (standard projection)
9	Type of operation	Type A: Emergency device with lever handle operation Type B: Emergency device with push pad operation
10	Field of door application	Category A: Outward opening: single & double exit doors; active & inactive leaf Category B: Outward opening: single exit door only Category C: Outward opening: double exit door; inactive door Category D: Inward opening: single exit door only

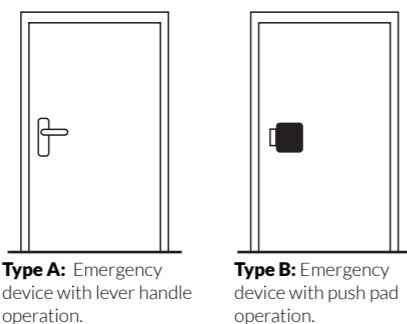

EN 1125:2008 Panic exit devices operated by a horizontal bar.

Digit	1	2	3	4	5	6	7	8	9	10
Description	Category of use	Durability	Door mass	Suitability for use on fire/smoke doors	Safety	Corrosion resistance	Security	Projection of operating element	Type of operation	Field of door application
Grade	3	7	7	B	1	4	2	2	A	A

Digit	Description	Grade of the product
1	Category of use	Grade 3: High frequency use by public and others with little incentive to exercise care.
2	Durability	Grade 6: 100.000 test cycles Grade 7: 200.000 test cycles
3	Door mass	Grade 5: Up to 100 kg Grade 6: Up to 200 kg Grade 7: Over 200 kg
4	Suitability for use on fire/smoke doors	Grade 0: Not approved for use on fire/smoke door assemblies Grade A: Suitable for use on smoke door assemblies, subject to satisfactory assessment of the contribution of the panic/emergency device to the smoke resistance of specified smoke door assemblies (see EN 1634-3) Grade B: Suitable for use on fire/smoke door assemblies, subject to satisfactory assessment of the contribution of the panic/emergency device to the fire resistance of specified fire/smoke door assemblies (see EN 1634-1)
5	Safety	Grade 1: All exit devices are required to satisfy the essential requirement of safety in use.
6	Corrosion resistance	Grade 3: High resistance (96 salt spray hours) Grade 4: Very high resistance (240 salt spray hours)
7	Security	Grade 2: 1000 N panic devices are primarily for the operation of a door from the inside. Safety considerations will always be given priority over security.
8	Projection of operating element	Grade 1: Projection up to 150 mm (large projection) Grade 2: Projection up to 100 mm (standard projection)
9	Type of operation	Type A: Panic device with push bar operation Type B: Panic device with touch bar operation
10	Field of door application	Category A: Outward opening: single & double exit doors; active & inactive leaf Category B: Outward opening: single exit door only Category C: Outward opening: double exit door; inactive door

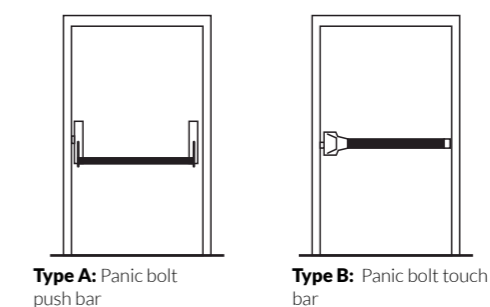
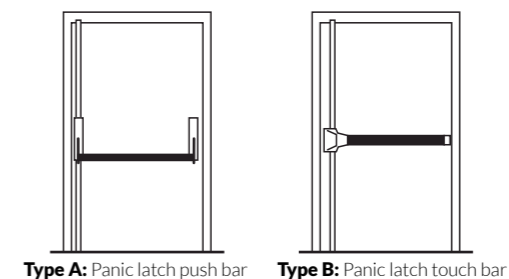

ELECTRIC STRIKES

Electric strikes are electromechanical devices used as an integral part of any access control system. They are installed in the doorframes avoiding unnecessary wiring in the door leaf.

The main function of an electric strike is to open any door through a single electrical pulse.

Since reliability is our main concern, we subject all our products to rigorous aging, pressure and weather tests in order to guarantee the security of a permanently locked door.

O&C's wide range of electric strikes are available for any kind of wooden, metal, plastic or aluminium door profile.

CODING

We have modified our product codes in order to make our team's and customer's work easier.

New electric strike item number (examples in red)



Model	Function	Coil	Keeper (K)	Cover (C)
5U	0	X	1	0
	1	Y		1
	2			
	3			
	4			
	6			
	8			

5U3X10

Keeper (K) and Cover (C)

CREATE YOUR IDEAL PRODUCT. Now you can customize your electric strike by selecting the keeper and the cover that best suits your needs. After choosing the desired product, the number that corresponds to the (K) and (C) to generate your reference is placed.

New faceplate item number (examples in red)



Typology	Model	Color	*Laser
Box	86	Brown	L
Short	28	X (Inox)	R
Angle	16	Z (Grey)	
Long	03		

S28XL

*Laser print

We can laser print your logo on the faceplate as an option. For this option add the letter L after the color category. If you wish the logo to be on both sides add the letter R.

Final item number



5U3X10S28XL

OUR MODELS



2 2S 3 3D

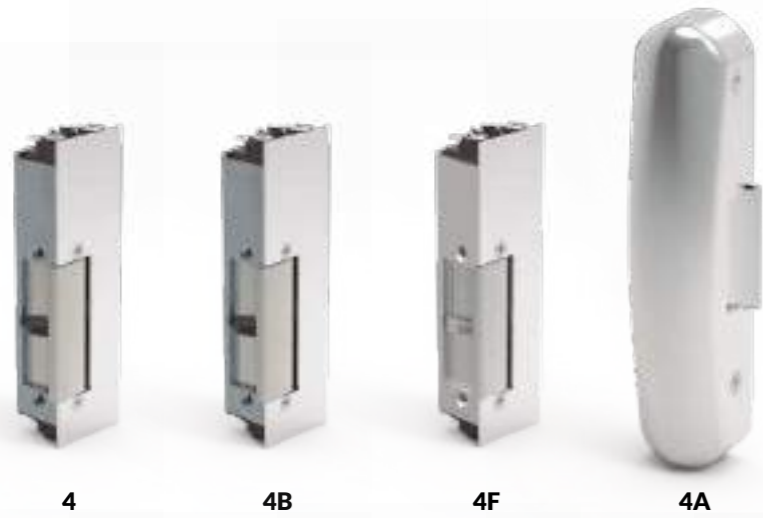

4 4B 4F 4A



5 5U 5E 5F 5UF 5EF



7 9 25 25E

NEW ITEMS

SELECT YOUR PRODUCT!

First select the model number, the function and add the coil that better suits your needs. Choose a single digit for the keeper and cover.
Example: If we want the Series 3 with Dual Voltage, fail-safe function, keeper 2 and standard cover. The result would be: **3D4W21**

Model	Function	Coils	Keeper	Cover																		
2	2L	0	B	C	D	E	F	G	H	L	M	N	P	S	V	W	X	Y	Z	0123	012	
		1	B	C	D	E	F	G	H	L	M	N	P	S	V	W	X	Y	Z	0123	012	
		2	B	C	D	E	F	G	H	L	M	N	P	S	V	W	X	Y	Z	01	012	
		3	B	C	D	E	F	G	H	L	M	N	P	S	V	W	X	Y	Z	01	012	
		4	B	C	D	E	F	G	H	L	M	N	P	S	V	W	X	Y	Z	0123	012	
		A	B	C	D	E	F	G	H	L	M	N	P	S	V	W	X	Y	Z	0123	012	
	2S(L/R)	0	B	C	D	E	F	G	H	L	M	N	P	S	V	W	X	Y	Z	0	0	
		4	B	C	D	E	F	G	H	L	M	N	P	S	V	W	X	Y	Z	0	0	
		A	B	C	D	E	F	G	H	L	M	N	P	S	V	W	X	Y	Z	0	0	
		B	B	C	D	E	F	G	H	L	M	N	P	S	V	W	X	Y	Z	0123	012	
3	3	0	B	C	D	E	F	G	H	L	M	N	P	S	V	W	X	Y	Z	1234	01	
		1	B	C	D	E	F	G	H	L	M	N	P	S	V	W	X	Y	Z	1234	01	
		2	B	C	D	E	F	G	H	L	M	N	P	S	V	W	X	Y	Z	1	01	
		3	B	C	D	E	F	G	H	L	M	N	P	S	V	W	X	Y	Z	1	01	
		4	B	C	D	E	F	G	H	L	M	N	P	S	V	W	X	Y	Z	1234	01	
		A	B	C	D	E	F	G	H	L	M	N	P	S	V	W	X	Y	Z	1234	01	
	3D	0	B	C	D	E	F	G	H	L	M	N	P	S	V	W	X	Y	Z	1234	01	
		1	B	C	D	E	F	G	H	L	M	N	P	S	V	W	X	Y	Z	1234	01	
		4	B	C	D	E	F	G	H	L	M	N	P	S	V	W	X	Y	Z	1234	01	
		B	B	C	D	E	F	G	H	L	M	N	P	S	V	W	X	Y	Z	1234	01	
4	4(L/R)	0	B	C	D	E	F	G	H	L	M	N	P	S	V	W	X	Y	Z	4	0	
		4	B	C	D	E	F	G	H	L	M	N	P	S	V	W	X	Y	Z	4	0	
		6	B	C	D	E	F	G	H	L	M	N	P	S	V	W	X	Y	Z	4	0	
		7*	B	C	D	E	F	G	H	L	M	N	P	S	V	W	X	Y	Z	4	0	
		8	B	C	D	E	F	G	H	L	M	N	P	S	V	W	X	Y	Z	4	0	
		9*	B	C	D	E	F	G	H	L	M	N	P	S	V	W	X	Y	Z	4	0	
		A	B	C	D	E	F	G	H	L	M	N	P	S	V	W	X	Y	Z	4	0	
		4B	0	B	C	D	E	F	G	H	L	M	N	P	S	V	W	X	Y	Z	4	0
			6	B	C	D	E	F	G	H	L	M	N	P	S	V	W	X	Y	Z	4	0
			8	B	C	D	E	F	G	H	L	M	N	P	S	V	W	X	Y	Z	4	0
	9		B	C	D	E	F	G	H	L	M	N	P	S	V	W	X	Y	Z	4	0	
	4F(L/R)	0	B	C	D	E	F	G	H	L	M	N	P	S	V	W	X	Y	Z	4	0	
		6	B	C	D	E	F	G	H	L	M	N	P	S	V	W	X	Y	Z	4	0	
	4A	0	B	C	D	E	F	G	H	L	M	N	P	S	V	W	X	Y	Z	6	1	
		1	B	C	D	E	F	G	H	L	M	N	P	S	V	W	X	Y	Z	6	1	
		2	B	C	D	E	F	G	H	L	M	N	P	S	V	W	X	Y	Z	6	1	
		3	B	C	D	E	F	G	H	L	M	N	P	S	V	W	X	Y	Z	6	1	
		4	B	C	D	E	F	G	H	L	M	N	P	S	V	W	X	Y	Z	6	1	
		6	B	C	D	E	F	G	H	L	M	N	P	S	V	W	X	Y	Z	6	1	
		7	B	C	D	E	F	G	H	L	M	N	P	S	V	W	X	Y	Z	6	1	
		8	B	C	D	E	F	G	H	L	M	N	P	S	V	W	X	Y	Z	6	1	
		9	B	C	D	E	F	G	H	L	M	N	P	S	V	W	X	Y	Z	6	1	
A		B	C	D	E	F	G	H	L	M	N	P	S	V	W	X	Y	Z	6	1		
B	B	C	D	E	F	G	H	L	M	N	P	S	V	W	X	Y	Z	6	1			
5	5	0	B	C	D	E	F	G	H	L	M	N	P	S	V	W	X	Y	Z	1234567	01^	
		1	B	C	D	E	F	G	H	L	M	N	P	S	V	W	X	Y	Z	1234567	01^	
		2	B	C	D	E	F	G	H	L	M	N	P	S	V	W	X	Y	Z	1	0	
		3	B	C	D	E	F	G	H	L	M	N	P	S	V	W	X	Y	Z	1	0	
		4	B	C	D	E	F	G	H	L	M	N	P	S	V	W	X	Y	Z	1234567	01^	
		6	B	C	D	E	F	G	H	L	M	N	P	S	V	W	X	Y	Z	1234567	01^	
		8	B	C	D	E	F	G	H	L	M	N	P	S	V	W	X	Y	Z	1234567	01^	
		5U	0	B	C	D	E	F	G	H	L	M	N	P	S	V	W	X	Y	Z	1234567	01^
			1	B	C	D	E	F	G	H	L	M	N	P	S	V	W	X	Y	Z	1234567	01^
			2	B	C	D	E	F	G	H	L	M	N	P	S	V	W	X	Y	Z	1	0
	3		B	C	D	E	F	G	H	L	M	N	P	S	V	W	X	Y	Z	1	0	
	5E	0	B	C	D	E	F	G	H	L	M	N	P	S	V	W	X	Y	Z	1234567	01^	
		1	B	C	D	E	F	G	H	L	M	N	P	S	V	W	X	Y	Z	1234567	01^	
		2	B	C	D	E	F	G	H	L	M	N	P	S	V	W	X	Y	Z	1	0	
		3	B	C	D	E	F	G	H	L	M	N	P	S	V	W	X	Y	Z	1	0	
		4	B	C	D	E	F	G	H	L	M	N	P	S	V	W	X	Y	Z	1234567	01^	
		6	B	C	D	E	F	G	H	L	M	N	P	S	V	W	X	Y	Z	1234567	01^	
		8	B	C	D	E	F	G	H	L	M	N	P	S	V	W	X	Y	Z	1234567	01^	
		9	B	C	D	E	F	G	H	L	M	N	P	S	V	W	X	Y	Z	1234567	01^	
	5F	0	B	C	D	E	F	G	H	L	M	N	P	S	V	W	X	Y	Z	12	01^	
		6	B	C	D	E	F	G	H	L	M	N	P	S	V	W	X	Y	Z	12	01^	
	5UF	0	B	C	D	E	F	G	H	L	M	N	P	S	V	W	X	Y	Z	12	01^	
6		B	C	D	E	F	G	H	L	M	N	P	S	V	W	X	Y	Z	12	01^		
5EF	0	B	C	D	E	F	G	H	L	M	N	P	S	V	W	X	Y	Z	12	01^		
	6	B	C	D	E	F	G	H	L	M	N	P	S	V	W	X	Y	Z	12	01^		
7	7(L/R)	0	B	C	D	E	F	G	H	L	M	N	P	S	V	W	X	Y	Z	4	0	
		4	B	C	D	E	F	G	H	L	M	N	P	S	V	W	X	Y	Z	4	0	
		6	B	C	D	E	F	G	H	L	M	N	P	S	V	W	X	Y	Z	4	0	
		8	B	C	D	E	F	G	H	L	M	N	P	S	V	W	X	Y	Z	4	0	
		A	B	C	D	E	F	G	H	L	M	N	P	S	V	W	X	Y	Z	4	0	
9	9(L/R)	0	B	C	D	E	F	G	H	L	M	N	P	S	V	W	X	Y	Z	12	0	
		2	B	C	D	E	F	G	H	L	M	N	P	S	V	W	X	Y	Z	12	0	
		3	B	C	D	E	F	G	H	L	M	N	P	S	V	W	X	Y	Z	12	0	
		4	B	C	D	E	F	G	H	L	M	N	P	S	V	W	X	Y	Z	12	0	
		A	B	C	D	E	F	G	H	L	M	N	P	S	V	W	X	Y	Z	12	0	
		B	B	C	D	E	F	G	H	L	M	N	P	S	V	W	X	Y	Z	12	0	
		12	B	C	D	E	F	G	H	L	M	N	P	S	V	W	X	Y	Z	12	0	
25	25	0	B	C	D	E	F	G	H	L	M	N	P	S	V	W	X	Y	Z	1	0	
		2	B	C	D	E	F	G	H	L	M	N	P	S	V	W	X	Y	Z	1	0	
		4	B	C	D	E	F	G	H	L	M	N	P	S	V	W	X	Y	Z	1	0	
		6	B	C	D	E	F	G	H	L	M	N	P	S	V	W	X	Y	Z	1	0	
		8	B	C	D	E	F	G	H	L	M	N	P	S	V	W	X	Y	Z	1	0	
	25E	0	B	C	D	E	F	G	H	L	M	N	P	S	V	W	X	Y	Z	1	0	
		2	B	C	D	E	F	G	H	L	M	N	P	S	V	W	X	Y	Z	1	0	
		4	B	C	D	E	F	G	H	L	M	N	P	S	V	W	X	Y	Z	1	0	
		6	B	C	D	E	F	G	H	L	M	N	P	S	V	W	X	Y	Z	1	0	
		8	B	C	D	E	F	G	H	L	M	N	P	S	V	W	X	Y	Z	1	0	

Functions

- 0. Fail-secure
- 1. Fail-secure with mechanical unlocking
- 2. Hold-open
- 3. Hold-open with mechanical unlocking
- 4. Fail-safe
- 6. Fail-secure with monitoring
- 7. Fail-secure with double monitoring
- 8. Fail-safe with monitoring
- 9. Fail-safe with double monitoring
- A. Internal hold-open
- B. Internal hold-open with mechanical unlocking

Coils

- B. 6-14 VAC
- C. 12 VAC
- D. 24 VAC
- E. 12 VDC
- F. 24 VDC
- G. 15-24 VDC (60 Hz)
- L. 8-14 VAC
- M. 12 VDC
- N. 24 VDC
- P. 12 VDC
- S. 8 VDC
- V. 12 VDC
- W. 12/24 VDC
- X. 9-24 VAC/DC
- Y. 22-28 VAC/DC
- Z. 6-28 VAC/DC

ELECTRIC STRIKES

REF.

Further details on pages 28 - 29

Further details on pages 34 - 35

*Din R on request. Further details on pages 42 - 45
Functions 7* and 9* do not work with 4R model.

FUNCTIONS

GLOSSARY

Electric strikes (also called electric latch release or electric door openers) replace a standard strike plate mounted on the door frame while electrically automating the opening of the lock.

Faceplates, in different shapes and finishes, allow the strike to be perfectly installed into any kind of frame.

Hold-open
This function allows unlocking with a single electric impulse and holds the strike unlocked until the door is opened.

Monitoring
This function displays the status of the door to your access control or interlocking system.

Mechanical unlocking
Activating this lever keeps the strike permanently opened until manually switched back.

Keepers (fixed or adjustable; deep or shallow) allow the strike to work perfectly with any kind of latch.

Electronic protection
A transil suppressor within the terminal block protects your access control system from current peaks.

Side-load
Is the pressure exerted on the keeper by an external force (door weight, wind, bad installation, etc.)

0



Fail-secure
The electric strike is unlocked when electrically activated.

1



Fail-secure with mechanical unlocking
The electric strike is unlocked when electrically activated. It features a mechanical lever for manual release.

6



Fail-secure with monitoring
The electric strike is unlocked when electrically activated. It features a microswitch that detects the status of the door (opened/closed).

7



Fail-secure with double monitoring
The electric strike is unlocked when electrically activated. It features 2 microswitches that detect the status of both the door (opened/closed) and the keeper (locked/unlocked).

2



Hold-open
The pin on the keeper allows the unlocking of the strike through a single electric impulse. The strike will stay unlocked until the actual opening of the door.

3



Hold-open with mechanical unlocking
The pin on the keeper allows the unlocking of the strike through a single electric impulse. The strike will stay unlocked until the actual opening of the door. It features a mechanical lever for manual release.

4



Fail-safe
The electric strike is locked when electrically activated.

8



Fail-safe with monitoring
The electric strike is locked when electrically activated. It features a microswitch that detects the status of the door (opened/closed).

9



Fail-safe with double monitoring
The electric strike is locked when electrically activated. It features 2 microswitches that detect the status of both the door (opened/closed) and the keeper (locked/unlocked).

A



Internal Hold-open
An internal device allows the unlocking of the electric strike through a single electric pulse. The electric strike will stay unlocked until the actual opening of the door.

B



Internal Hold-open with mechanical unlocking
An internal device allows the unlocking of the electric strike through a single electric impulse. The strike will stay unlocked until the actual opening of the door. It features a mechanical lever for manual release.

DIN 107

DIN 107 Standard

To check the direction of an opening door we must consider the side where the hinges are arranged. The visible position of the hinges on the right will determine DIN Right and the visible position of the hinges in the left determines DIN Left.

Hinges Left: DIN L
(Order DIN L electric strike)

Hinges Right: DIN R
(Order DIN R electric strike)



INSTALLATION OF AN ELECTRIC STRIKE

The installation of electric strikes is very easy.

You just have to connect the cables in your doorframe to the terminal block. Set the electric strike into its nook. Then it's just a matter of screwing the faceplate into position and you're set to go.



SERIES 2

THE ORIGINAL ELECTRIC STRIKE!

Going back to our roots

We have been manufacturing Series 2 since 1989.

This emblematic product is a classic in the hardware business and is available in a vast range of models.



Technical characteristics

Break-in resistance (keeper's pressure)	3.500 N
Dynamic strength (door impact)	4.400 N
Endurance rating ☐ (cycles with no side-load)	200.000
Endurance rating ☒ (cycles with 120 N side-load AC)	200.000
Temperature	- 25 °C to + 70 °C
Complies with the directive:	2014/30/UE 2011/65/UE

According to EN 14846 standard

Fail-secure:	3 X 2 0 0 L 0 0 0
Fail-safe:	3 C 2 0 0 L 0 0 0

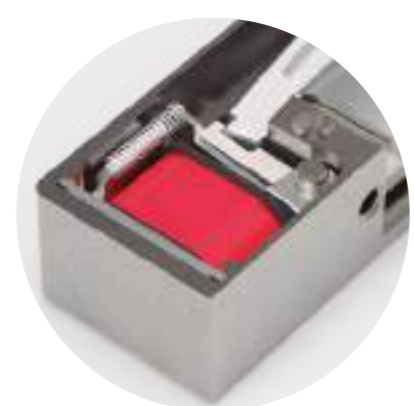
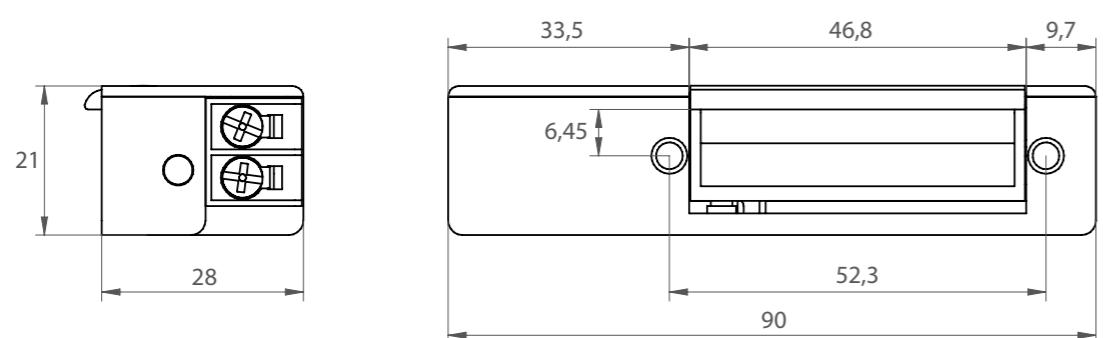

T SHAPED COIL
We attach the coil without screws. Our T shape design protects the coil from vibrations or movements inside the housing.



POSITIVE OR NEGATIVE?
The connection is not polarized. This makes the installation of our electric strike safe and easy. Just connect it to the proper voltage and you are ready to go!



BIGGER TERMINAL BLOCK
External curved design for the terminal block in order to avoid short circuit with the housing. Internal cable protected and positioned inside the housing to avoid any damage.

2S

Surface electric strike

The Surface electric strikes are built with a cavity designed to house the bolt and facilitate the automatic access.

They are available for right or left DIN doors, and also for horizontal (90 mm) and vertical (120 mm) mechanical locks. With a wide variety of functions and voltages, these electric strikes quickly unlock standard doors with low power consumption.

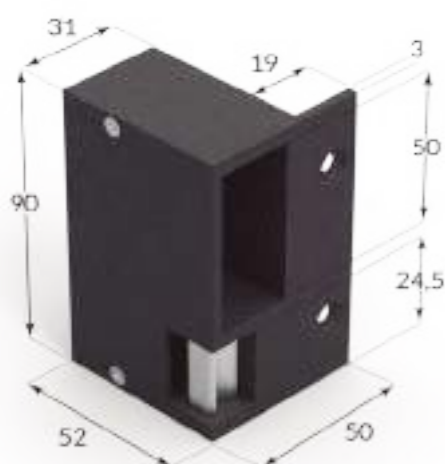

B09(Color)
DIN R



B10(Color)
DIN L

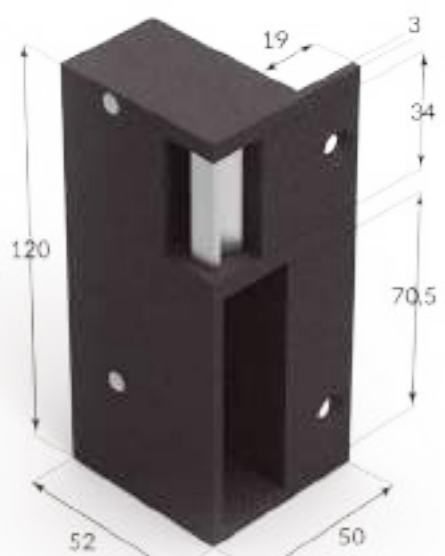

B11(Color)
DIN R



B12(Color)
DIN L

Available colors
Remember to add the desired color
behind the reference. For example:
B10 in Black would be **B10K**

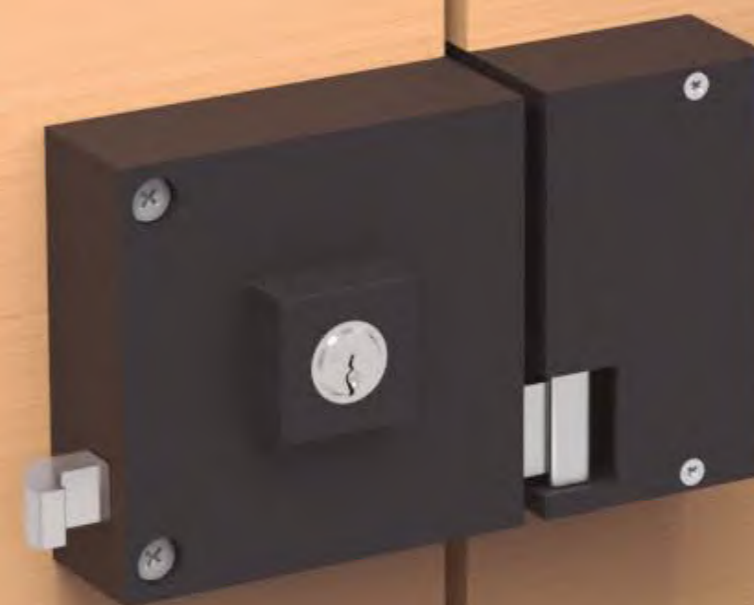
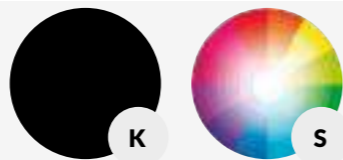

NEW ITEM NUMBERS (EXAMPLE)

Model	Function	Coil	Keeper	Cover
2L	0	B	(K)	(C)

ITEM NUMBERS AND FEATURES

Functions

0. Fail-secure



2 DIN L *	2S DIN R	2S DIN L
2L0B(K)(C)	2SR0B00 (Box)	2SLOB00 (Box)
2L0C(K)(C)	2SR0C00 (Box)	2SLOC00 (Box)
2L0D(K)(C)	2SR0D00 (Box)	2SLOD00 (Box)
2L0E(K)(C)	2SR0E00 (Box)	2SLOE00 (Box)
2L0F(K)(C)	2SR0F00 (Box)	2SLOF00 (Box)
2L0G(K)(C)	2SR0G00 (Box)	2SLOG00 (Box)
2L0H(K)(C)	2SR0H00 (Box)	2SLOH00 (Box)

*DINR can be mounted by turning the strike 180°

Remember to choose the Box. You can check Faceplates page.
B09(+ Color) / B11(+ Color) / B10(+ Color) / B12(+ Color)

1. Fail-secure with mechanical unlocking



2L1B(K)(C)	-	-
2L1C(K)(C)	-	-
2L1D(K)(C)	-	-
2L1E(K)(C)	-	-
2L1F(K)(C)	-	-
2L1G(K)(C)	-	-
2L1H(K)(C)	-	-

2. Hold-open



2L2B(K)(C)	-	-
2L2C(K)(C)	-	-
2L2D(K)(C)	-	-
2L2G(K)(C)	-	-
2L2H(K)(C)	-	-

3. Hold-open with mechanical unlocking



2L3B(K)(C)	-	-
2L3C(K)(C)	-	-
2L3D(K)(C)	-	-
2L3G(K)(C)	-	-
2L3H(K)(C)	-	-

4. Fail-safe



2L4E(K)(C)	2SR4E00 (Box)	2SL4E00 (Box)
2L4F(K)(C)	2SR4F00 (Box)	2SL4F00 (Box)

A. Internal hold-open



2LAB(K)(C)	2SRAB00 (Box)	2SLAB00 (Box)
2LAC(K)(C)	2SRAC00 (Box)	2SLAC00 (Box)
2LAD(K)(C)	2SRAD00 (Box)	2SLAD00 (Box)
2LAG(K)(C)	2SRAG00 (Box)	2SLAG00 (Box)
2LAH(K)(C)	2SRAH00 (Box)	2SLAH00 (Box)

B. Internal hold-open with mechanical unlocking



2LBB(K)(C)	-	-
2LBC(K)(C)	-	-
2LBD(K)(C)	-	-
2LBG(K)(C)	-	-
2LBH(K)(C)	-	-

Coils

Electrical characteristics

	B	C	D	E	F	G	H
Electrical data	6-14V AC/DC	12V AC	24V AC	12V DC	24V DC	15-24V AC (60Hz)	8-14V AC/DC
Continuous duty	< 1 min	< 1 min	< 1 min	ED 100%	ED 100%	< 1 min	< 1 min
Transient Voltage Suppressor (TVS)	-	-	-	-	-	-	-
Rated resistance	8 Ω	30 Ω	60 Ω	60 Ω	220 Ω	47 Ω	12 Ω
Current consumption AC	0,53 A ... 6V 1 A 12V 1,24 A ... 14V	0,28 A	0,28 A	-	-	0,23 A ... 15V 0,36 A ... 24V	0,47 A ... 8V 0,71 A ... 12V 0,82 A ... 14V
Current consumption DC (stabilized)	0,75 A ... 6V 1,5 A 12V 1,75 A ... 14V	-	-	0,2 A	0,11 A	-	0,67 A ... 8V 1 A 12V 1,17 A ... 14V
Maximum side-load on AC	12V - 120 N	120 N	120 N	-	-	15V - 120 N	12V - 120 N
Maximum side-load on DC (stabilized)	12V - 10 N	-	-	10 N	10 N	-	12V - 10 N

Creating new item numbers

Remember to replace the (K) and (C) that correspond to the Keeper and the Cover of the product by the desired number. For example: 2L0B(K)(C) would be **2L0B11** if we chose Keeper 1 and Cover 1.

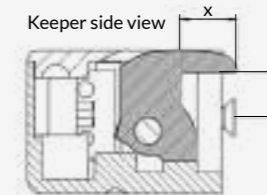

Dimension X
Keeper depth

Dimension Y
Keeper's adjustability from minimum to maximum

Section view

Keeper (K)

0				Fixed keeper made of zamak Suitable for all functions. (features 2 / 3 manufactured with a hole) X= 8,25 mm Y= 6,5 mm
1				Adjustable keeper made of zamak Suitable for all functions. Features (features 2 / 3 manufactured with a hole) X=7,75 mm Y= 6,5 to 9,7 mm
2				Adjustable keeper made of zamak Suitable for features 0 / 1 / 4 / A / B X= 6,15 mm Y= 6,5 to 9,7 mm
3				Adjustable keeper made of zamak Suitable for features 0 / 1 / 4 / A / B X=13,3 mm Y= 6,5 to 9,7 mm

Cover (C)

0				20 mm
1	Nylon	SST	SST	

SERIES 3

THE EVOLUTION!

A step beyond

With more features than its predecessor, the new Series 3 has been redesigned to integrate all its elements into a smaller and more compact model. Completely symmetric now it incorporates a new configurable system that allows a dual voltage.



3

Instantaneous unlocking

Forgetting about DIN

Our engineers have reimagined the electric strikes to make them reversible. Thanks to their symmetrical build and tinier box, we have been able to create a product suitable for any door. A brilliant system of internal levers provides a safe and durable unlocking for doors in public use.

SYMMETRIC DESIGN



Technical characteristics

Break-in resistance (keeper's pressure)	3.500 N
Dynamic strength (door impact)	4.400 N
Endurance rating <input type="checkbox"/> (cycles with no side-load)	200.000
Endurance rating <input checked="" type="checkbox"/> (cycles with 120 N side-load AC)	200.000
Temperature	- 25 °C to + 70 °C
Complies with the directive:	2014/30/UE 2011/65/UE

According to EN 14846 standard

Fail-secure:	3 X 2 0 0 L 0 0 0
Fail-safe:	3 C 2 0 0 L 0 0 0

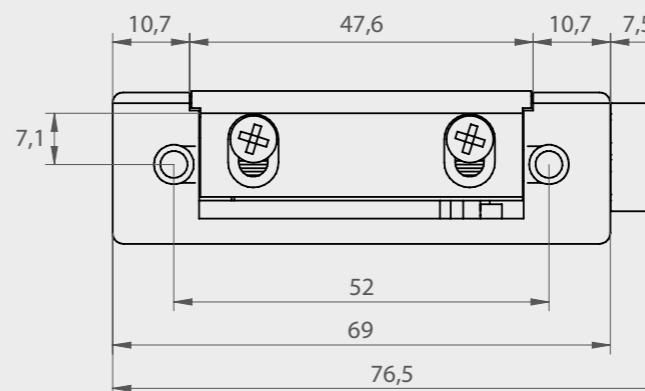
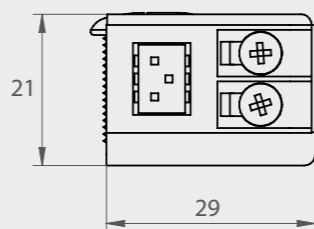

3D

Dual performance

Double function.
Twice as good!

The objective was clear: to reduce storage costs and save on commuting during installation. The most versatile model of Series 3 for its dual function 12 / 24V DC. It includes a pin selector to configure the desired voltage.

DUAL VOLTAGE



ELECTRONIC PROTECTION

Our aim is to guarantee a longer lifespan for your electric strike. Our DC 100% coils are equipped with an electronic protection to prevent electrical overload.

REVERSIBILITY: GOODBYE DIN 107

Reliability assured with the coil's new position. The internal mechanism is more accurate and allows our product to work on any kind of door, whether it opens to the right or to the left.

INGENIOUS AUTOMATIC SYSTEM

The goal was to unify the keeper with the automatic switch. When adjusting the keeper of the electric strike, this new automatic system will move alongside it to avoid gaps and provide better contact with the door latch.

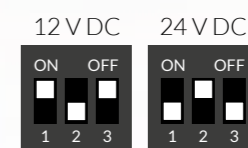

DUAL VOLTAGE
Electrical adjustment depending on the position of the pins.

NEW ITEM NUMBERS (EXAMPLE)

Model	Function	Coil	Keeper	Cover
3	0	B	(K)	(C)

ITEM NUMBERS AND FEATURES

Functions

3

3D



30B(K)(C)
30D(K)(C)
30E(K)(C)
30F(K)(C)
30H(K)(C)
30S(K)(C)

0. Fail-secure



3D0W(K)(C)



31B(K)(C)
31D(K)(C)
31E(K)(C)
31F(K)(C)
31H(K)(C)
31S(K)(C)

1. Fail-secure with mechanical unlocking



3D1W(K)(C)



32B(K)(C)
32D(K)(C)
32E(K)(C)
32H(K)(C)
32S(K)(C)

2. Hold-open



33B(K)(C)
33D(K)(C)
33E(K)(C)
33H(K)(C)
33S(K)(C)

3. Hold-open with mechanical unlocking



34E(K)(C)
34F(K)(C)

4. Fail-safe



3D4W(K)(C)



3AB(K)(C)
3AD(K)(C)
3AH(K)(C)
3AS(K)(C)

A. Internal hold-open



3BB(K)(C)
3BD(K)(C)
3BH(K)(C)
3BS(K)(C)

B. Internal hold-open with mechanical unlocking

Coils

Electrical characteristics

	B	D	E	F	H	S	W
Electrical data	6-14V AC/DC	24V AC	12V DC	24V DC	8-14V AC/DC	8V DC	12-24V AC 12-24V DC
Continuous duty	< 1 min	< 1 min	ED 100%	ED 100%	< 1 min	ED 100%	AC: < 1 min DC: ED 100%
Transient Voltage Suppressor (TVS)	-	-	SI	SI	-	SI	SI
Rated resistance	8,5 Ω	50 Ω	50 Ω	185 Ω	14 Ω	25 Ω	12V - 35 Ω 24V - 140 Ω
Current consumption AC	0,50 A ... 6V 1 A ... 12V 1,16 A ... 14V	0,34 A	.	.	0,4 A ... 8V 0,61 A ... 12V 0,71 A ... 14V	-	0,24 A ... 12V 0,12 A ... 24V
Current consumption DC (stabilized)	0,71 A ... 6V 1,40 A ... 12V 1,65 A ... 14V	-	0,24 A	0,13 A	0,57 A ... 8V 0,86 A ... 12V 1 A ... 14V	0,32 A ... 8V	0,34 A ... 12V 0,17 A ... 24V
Maximum side-load on AC	12V - 120 N	120 N	-	-	12V - 120 N	-	120 N
Maximum side-load on DC (stabilized)	12V - 10 N	-	10 N	10 N	12V - 10 N	10 N	10 N

Creating new item numbers

Remember to replace the (K) and (C) that correspond to the Keeper and the Cover of the product by the desired number. For example:
30B(K)(C) would be **30B11** if we chose Keeper 1 and Cover 1.

Keeper side view



Dimension X
Keeper depth

Dimension Y
Keeper's adjustability from minimum to maximum

Section view

Keeper (K)

1				Adjustable keeper made of zamak Suitable for features 0 / 1 / 4 / A / B X= 5,4 mm Y= 7,1 a 10,1 mm (An aperture suitable for features 2 / 3) X= 6,15 mm Y= 7,1 a 10,1 mm
2				Adjustable keeper made of zamak Suitable for features 0 / 1 / 4 / A / B X= 8 mm Y= 7,1 a 10,1 mm
3				Adjustable keeper made of zamak Suitable for features 0 / 1 / 4 / A / B X= 13,5 mm Y= 7,1 a 10,1 mm
4				Fixed keeper made of zamak Suitable for features 0 / 1 / 4 / A / B X= 5,4 mm Y= 7,1 mm

Cover (C)

0	Nylon	
1	Zamak	

SERIES 4 REINFORCED!

Double everything to keep facilities safe

Series 4 has been strengthened to provide a greater level of protection.

This electric strike is widely used by access control systems, door manufacturers and maintenance companies.



4

Bigger size

We have a solid base

For heavier doors or doors that are repeatedly opening and closing we created a stronger, more resilient electric strike. We increased the hardness by adding more material to the housing while strengthening the series with a 4 point support to better distribute its mechanical stress.

4B

Not even earthquakes can stop us!

Our vibration resistance will rock your world

An ingenious swivel system in the short lever increases the invulnerability of your facilities, avoiding unwanted vibrations that could affect the proper performance of your electric strike.



4F

Stay cool

Fire won't melt us!

The key is in the ingredients: Manufacturing fire resistant electric strikes requires experts in material properties. Our engineers have found an alloy that provides optimal resistance to the highest temperatures. Our fire strikes protect people's lives by withstanding temperatures up to 1.150°C for 60 minutes.

Technical characteristics 4F

Break-in resistance (keeper's pressure) 8.000 N

Fire resistant 60 min.

Accredited with EN 14846 certificate

Fail-secure: 3 C 1 D 0 L 0 0 0

Fail-safe with micro: 3 C 1 D 0 L 0 1 0

0432-CPR-00454-01

Technical characteristics

Break-in resistance (keeper's pressure) 6.500 N

Dynamic strength (door impact) 4.400 N

Endurance rating (cycles with no side-load) 200.000

Endurance rating (cycles with 120 N side-load AC) 200.000

Temperature - 25 °C to + 70 °C

Complies with the directive:
2014/30/UE
2011/65/UE

According to EN 14846 standard

Fail-secure: 3 X 1 0 0 L 0 0 0

Fail-safe: 3 C 1 0 0 L 0 0 0

Fail-secure with micro: 3 X 1 0 0 L 0 1 0

Fail-safe with micro: 3 C 1 0 0 L 0 1 0

Important
Install the electric strike so that the coil is positioned at the top.

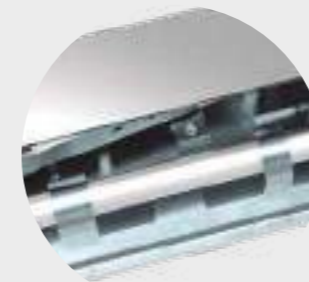
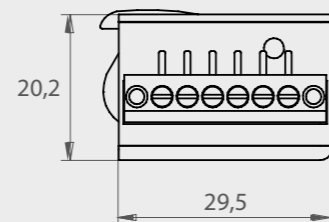

THE SECRET IS IN THE 4
In order to create a model that would be appreciated by any technical expert, we focused on the little details that offer a higher level of security as a whole. We are the only manufacturer to add 4 support points to the keeper to distribute the strain, making ours the strongest electric strike of its category.



LOW ENERGY CONSUMPTION, HIGHER UNLOCKING POWER
The Series 4 unlocks the internal levers with a double inner coil that has the lowest power consumption of the market.



DOOR AND INTERNAL LEVER STATUS DETECTION
We added two microswitches inside the mechanism to provide information about the status of the door and the position of the internal levers. This way we ensure there is no possible external manipulation of the electric strike.

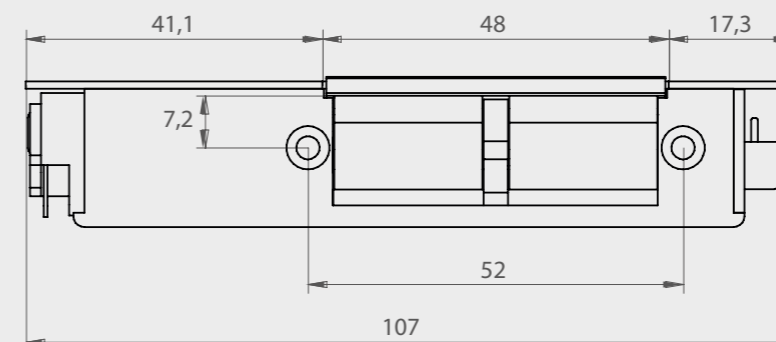

4A

Panic bars you will love!

Perfect choice to manage emergency doors

The electric strike has been designed to fit in the curved latch of panic bars. Specially built to be used in emergency exit doors and to gain access through an access control system.



Compatible with panic bars:
CISA, JPM,
ISEO, SAVIO,
VACHETTE, TESA

B86(Color)

B87(Color)

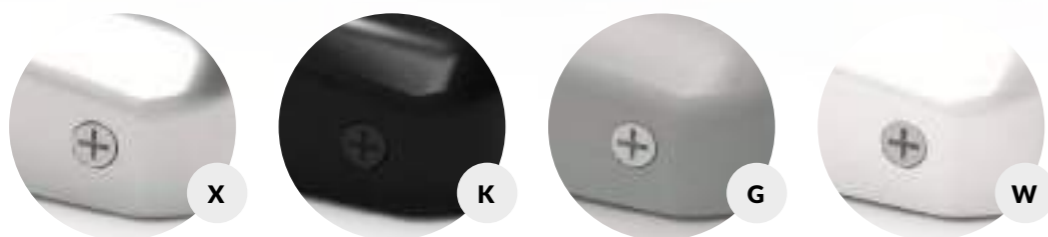

Remember to add the desired color behind the reference.
For example: B87 in Black would be **B87K**

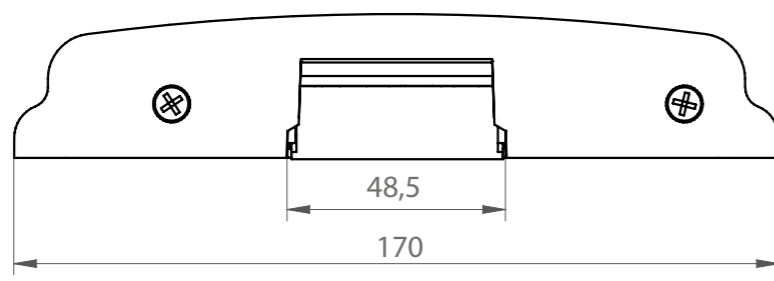
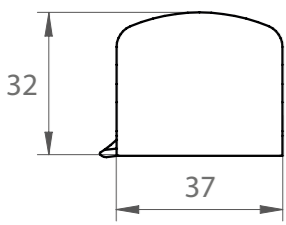
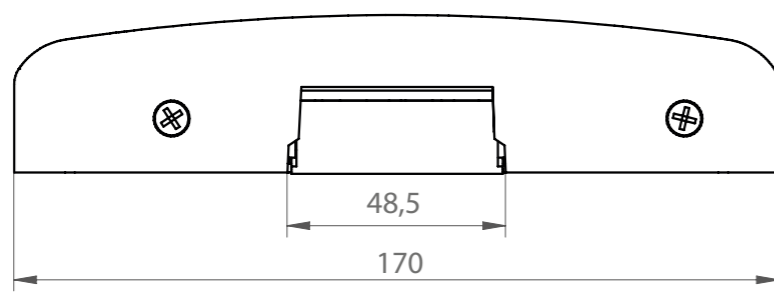
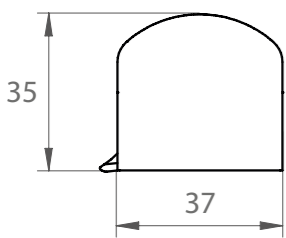

BEAUTIFUL FROM ANY PERSPECTIVE

An elegant design that boosts visual architecture. We got rid of square concepts to pursue round shapes.

4 COLORS

Everyone's tastes are different. That is why we offer four fantastic colors you can choose from: a shiny chrome, an elegant black, a matte grey and a dazzling white.

EXTREME PROTECTION

An iron structure holds the box and the electric strike firmly. The box can withstand strong impacts and any sort of manipulation without damaging the interior.



Technical characteristics 4A

Break-in resistance (keeper's pressure)	4.000 N
Endurance rating <input type="checkbox"/> (cycles with no side-load)	200.000
Endurance rating <input checked="" type="checkbox"/> (cycles with 120 N side-load AC)	200.000
Temperature	- 25 °C to + 70 °C

Complies with the directive:
2014/30/UE
2011/65/UE

According to EN 14846 standard:

Fail-secure:	3 X 1 0 0 L 0 0 0
Fail-safe:	3 C 1 0 0 L 0 0 0
Fail-secure with micro:	3 X 1 0 0 L 0 1 0
Fail-safe with micro:	3 C 1 0 0 L 0 1 0

NEW ITEM NUMBERS (EXAMPLE)

Model	Function	Coil	Keeper	Cover
4B	0	N	4	0

ITEM NUMBERS AND FEATURES

Functions	4 & 4B	4F	4A	4 DIN R	4 DIN L	4B DIN L	4F DIN R	4F DIN L	4A + Box
0. Fail-secure				4R0D40 4R0H40 4R0L40 4R0M40 4R0N40 4R0P40	4L0D40 4L0H40 4L0L40 4L0M40 4L0N40 4L0P40	4B0N40 4B0V40	4FR0D40 4FR0H40 4FR0L40 4FR0M40 4FR0N40 4FR0P40	4FL0D40 4FL0H40 4FL0L40 4FL0M40 4FL0N40 4FL0P40	4A0D61(Box) 4A0H61(Box) 4A0L61(Box) 4A0M61(Box) 4A0N61(Box) 4A0P61(Box)
1. Fail-secure with mechanical unlocking	-	-		-	-	-	-	-	4A1B61(Box) 4A1C61(Box) 4A1D61(Box) 4A1E61(Box) 4A1F61(Box) 4A1G61(Box) 4A1H61(Box)
2. Hold-open	-	-		-	-	-	-	-	4A2B61(Box) 4A2C61(Box) 4A2D61(Box) 4A2G61(Box) 4A1H61(Box)
3. Hold-open with mechanical unlocking	-	-		-	-	-	-	-	4A3B61(Box) 4A3C61(Box) 4A3D61(Box) 4A3G61(Box) 4A3H61(Box)
4. Fail-safe		-		4R4M40 4R4N40 4R4P40	4L4M40 4L4N40 4L4P40	-	-	-	4A4M61(Box) 4A4N61(Box) 4A4P61(Box)
6. Fail-secure with monitoring				4R6D40 4R6H40 4R6L40 4R6M40 4R6N40 4R6P40	4L6D40 4L6H40 4L6L40 4L6M40 4L6N40 4L6P40	4B6N40 4B6V40	4FR6D40 4FR6H40 4FR6L40 4FR6M40 4FR6N40 4FR6P40	4FL6D40 4FL6H40 4FL6L40 4FL6M40 4FL6N40 4FL6P40	4A6D61(Box) 4A6H61(Box) 4A6L61(Box) 4A6M61(Box) 4A6N61(Box) 4A6P61(Box)
7. Fail-secure with double monitoring		-		-	4L7D40 4L7H40 4L7L40 4L7M40 4L7N40 4L7P40	-	-	-	4A7D61(Box) 4A7H61(Box) 4A7L61(Box) 4A7M61(Box) 4A7N61(Box) 4A7P61(Box)
8. Fail-safe with monitoring		-		4R8M40 4R8N40 4R8P40	4L8M40 4L8N40 4L8P40	-	-	-	4A8M61(Box) 4A8N61(Box) 4A8P61(Box)
9. Fail-safe with double monitoring		-		-	4L9M40 4L9N40 4L9P40	-	-	-	4A9M61(Box) 4A9N61(Box) 4A9P61(Box)
A. Internal hold-open		-		4RAD40 4RAH40 4RAL40	4LAD40 4LAH40 4LAL40	-	-	-	4AAD61(Box) 4AAH61(Box) 4AAL61(Box)
B. Internal hold-open with mechanical unlocking	-	-		-	-	-	-	-	4ABB61(Box) 4ABC61(Box) 4ABD61(Box) 4ABG61(Box) 4ABH61(Box)

Remember to choose the Box B86 (Color) or B87 (Color) in Faceplates page.



Coils

Electrical characteristics

	B	C	D	E	F	G
Electrical data	6-14V AC/DC	12V AC	24V AC	12V DC	24V DC	15-24V AC (60 Hz)
Continuous duty	< 1 min	< 1 min	< 1 min	ED 100%	ED 100%	< 1 min
Transient Voltage Suppressor (TVS)	-	-	-	-	-	-
Rated resistance	8 Ω	30 Ω	60 / 70 Ω	60 Ω	220 Ω	47 Ω
Current consumption AC	0,53 A 6V 1 A 12V 1,24 A 14V	0,28 A	0,28 / 0,24 A	-	-	0,23 A 15V 0,36 A 24V
Current consumption DC (stabilized)	0,75 A 6V 1,5 A 12V 1,75 A 14V	-	-	0,20 A	0,11 A	-
Maximum side-load on AC	12V - 120 N	120 N	120 N	-	-	15V - 120 N
Maximum side-load on DC (stabilized)	12V - 10 N	-	-	10 N	10 N	-
Compatible coils for	4A	4A	4, 4F, 4A	4A	4A	4A

H	L	M	N	P	V	
8-14V AC/DC	8-14V AC/DC	12V DC	24V DC	12V DC	12V DC	Electrical data
< 1 min	< 1 min	ED 100%	ED 100%	ED 100%	ED 100%	Continuous duty
-	-	Si	Si	Si	Si	Transient Voltage Suppressor (TVS)
12 Ω	20 Ω	70 Ω	240 Ω	54 Ω	48 Ω	Rated resistance
0,47 A 8V 0,71 A 12V 0,82 A 14V	0,28 A 8V 0,42 A 12V 0,49 A 14V	-	-	-	-	Current consumption AC
0,67 A 8V 1 A 12V 1,17 A 14V	0,4 A 8V 0,6 A 12V 0,7 A 14V	0,17 A	0,1 A	0,22 A	0,25 A	Current consumption DC (stabilized)
12V - 120 N	12V - 120 N	-	-	-	-	Maximum side-load on AC
12V - 10 N	12V - 10 N	10 N	10 N	10 N	10 N	Maximum side-load on DC (stabilized)
4A	4, 4F, 4A	4, 4F, 4A	4, 4B, 4F, 4A	4, 4F, 4A	4B	Compatible coils for



Thickness **C86**
6 units included



Anti-vandalism base

B86X

Our special keepers and covers ensure the best fitting possible

Keeper section view



Dimension X
Keeper depth

Dimension Y
Keeper's adjustability from minimum to maximum

Section view

Keeper

4



Fixed keeper made of microfusion
X= 9,48 mm
Y= 13 mm

6



Fixed keeper made of zamak
X= 9,59 mm
Y= 15,4 mm

Cover

0 SST

1 Anti-vandalism base for B86 and B87

SERIES 5 REVOLUTION!

High tech quality

We have designed the most compact electric strike without sacrificing any of the quality or safety offered by our other products, reinventing every element to make it smaller. Thus Series 5 is the perfect match for narrow aluminium, PVC or timber profiles.

This strike features new internal mechanisms to measure up to the highest technical requirements.



5U



5



5F



5UF



5E



5EF

5

Compact

Versatile and functional

This new generation of electric strikes will surely surprise you: we have crafted the Series 5 from scratch, focusing on a simple and functional design.

5U

Where less is more!

Small and universal

With less models we reach a wider range of solutions, making the 5U the ideal choice for projects with several voltages. This electric strike simplifies purchasing forecast and compatibility with technical requirements.

The new internal design allows the opening with side-load up to 200 N.

16 MM
WIDTH

UP TO
200 N
SIDE - LOAD
AC

9-24 V
22-28 V
AC / DC



Technical characteristics

Break-in resistance (keeper's pressure)	4.800 N
Dynamic strength (door impact)	4.400 N
Endurance rating \square (cycles with no side-load)	200.000
Temperature	- 25 °C to + 70 °C
Complies with the directive:	2014/30/UE 2011/65/UE

According to EN14846 standard:

Fail-secure / Fail-safe:	3 C 3 0 0 H 0 0 0
Fail-secure / Fail-safe with micro:	3 C 3 0 0 H 0 1 0

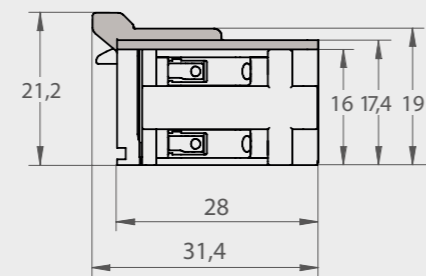

New Latch guide



THE PERFECT RADIAL ROTATION
The new radial system allows the keeper to rotate on its own axis. When the rotation is performed inside the mechanism of the box the installation of an electric strike becomes easier, less time consuming and more aesthetically pleasing.

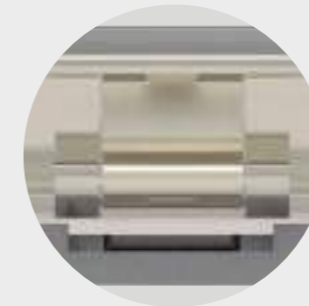

NEW HOLD-OPEN SYSTEM
Designers and engineers at O&C had the challenge to create a hold-open system that was both durable and able to adapt to all kinds of door latches. The new automatic system is more reliable, simple and effective.



REVOLUTIONARY UNLOCKING LEVER
Our passion for every little detail made us enhance the traditional mechanical unlocking system of electric strikes. Now it's much more precise and durable.

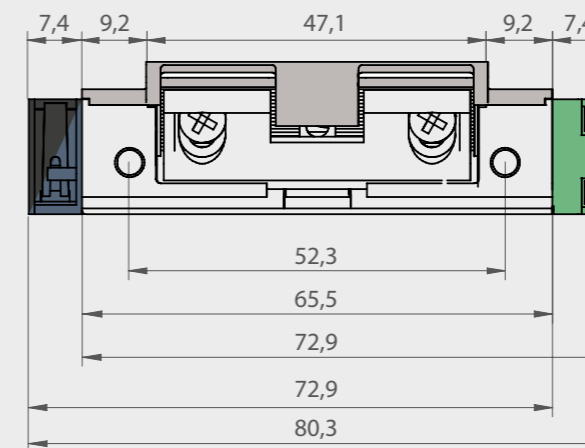

5E

Pure innovation

The world's first electronic strike!

The future has finally arrived. After years of research and creative effort we present the first electronic strike on the market. Specially designed to adapt to any access control system: simple and unique.

Now electronically improved and with less noise!

UP TO
400 N
SIDE - LOAD
AC - DC

ELECTRONIC
MICROCHIP

6-28 V
AC / DC
100%



5F

Pure strength!

Resistance within reach

Made entirely out of an extremely resistant alloy that adapts to the geometric complexity of the electric strike. Every little detail has been passionately designed to improve its efficiency on fire and high security doors.

5UF

Passionate about the details!

Compact and universal

The design of our new universal coil offers the advantage of unifying models and performing faster installations. Making this the most versatile electric strike for fire solutions yet.

16 MM
DE ANCHO

UPTO
200 N
SIDE - LOAD
AC

9-24 V
22-28 V
AC / DC



Technical characteristics

Break-in resistance (keeper's pressure)	8.000 N
Dynamic strength (door impact)	4.400 N
Endurance rating <input type="checkbox"/> (cycles with no side-load)	200.000
Fire resistant	90 min.
Temperature	- 25 °C to + 70 °C

Complies with the directive:
2014/30/UE
2011/65/UE

Accredited with EN14846 certificate:

Fail-secure / Fail-safe: **3 C 3 E 0 H 0 0 0**

Fail-secure / Fail-safe with micro: **3 C 3 E 0 H 0 1 0**

0432-CPR-00406-01.1

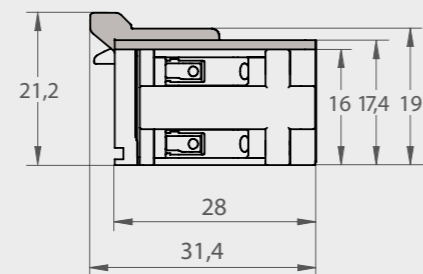

New Latch guide



INTERCHANGEABLE MICRO SWITCH

The monitoring that detects the status of the door has now an interchangeable position to provide a more comfortable and secure installation.



THE TOUGHEST MATERIAL

Fully manufactured in a steel alloy that can withstand high temperatures and helps maintain fire doors sealed.

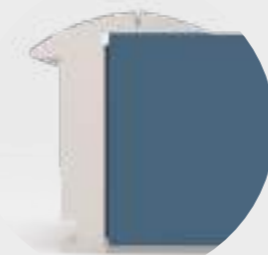

OPTIMAL REGULATION

An ingenious redesign of the mechanism housing has increased the depth of the keeper to 6mm and 3mm adjustability while maintaining its perfect radial rotation.

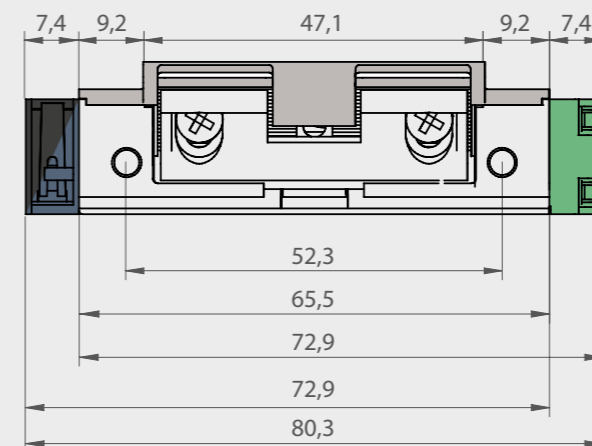

5EF

The future is electronic!

Unique

Our engineers at O&C found a sophisticated and advanced solution for any fire door that requires an extra layer of protection: to include a microprocessor that unlocks the door from 6 to 28V AC / DC. While increasing the side-load up to 400 N. This powerful chip is also responsible for controlling the temperature of the electronic strike so it doesn't exceed 40 °C.

UPTO
400 N
SIDE - LOAD
AC - DC

ELECTRONIC
MICROCHIP

6-28 V
AC / DC
100%



NEW ITEM NUMBERS (EXAMPLE)

Model	Function	Coil	Keeper	Cover
5U	0	X	(K)	(C)

ITEM NUMBERS AND FEATURES

Functions

Creating new item numbers

Remember to replace the (K) and (C) that correspond to the Keeper and the Cover of the product by the desired number. See the next page for an easy selection. For example: 5U0X(K)(C) would become **5U0X21** if we chose Keeper 2 and Cover 1.



	5y5U	5E	5Fy5UF	5EF						
0. Fail-secure					50B(K)(C) 50D(K)(C) 50E(K)(C) 50F(K)(C) 50H(K)(C)	5U0X(K)(C) 5U0Y(K)(C)	5E0Z(K)(C)	5F0B(K)(C) 5F0D(K)(C) 5F0E(K)(C) 5F0F(K)(C) 5F0H(K)(C)	5UF0X(K)(C) 5UF0Y(K)(C)	5EF0Z(K)(C)
1. Fail-secure with mechanical unlocking					51B(K)(C) 51D(K)(C) 51E(K)(C) 51F(K)(C) 51H(K)(C)	5U1X(K)(C) 5U1Y(K)(C)	5E1Z(K)(C)	-	-	-
2. Hold-open					52B(K)(C) 52D(K)(C) 52E(K)(C) 52F(K)(C) 52H(K)(C)	5U2X(K)(C) 5U2Y(K)(C)	5E2Z(K)(C)	-	-	-
3. Hold-open with mechanical unlocking					53B(K)(C) 53D(K)(C) 53E(K)(C) 53F(K)(C) 53H(K)(C)	5U3X(K)(C) 5U3Y(K)(C)	5E3Z(K)(C)	-	-	-
4. Fail-safe					54E(K)(C) 54F(K)(C)	5U4X(K)(C) 5U4Y(K)(C)	5E4Z(K)(C)	-	-	-
6. Fail-secure with monitoring					56B(K)(C) 56D(K)(C) 56E(K)(C) 56F(K)(C) 56H(K)(C)	5U6X(K)(C) 5U6Y(K)(C)	5E6Z(K)(C)	5F6B(K)(C) 5F6D(K)(C) 5F6E(K)(C) 5F6F(K)(C) 5F6H(K)(C)	5UF6X(K)(C) 5UF6Y(K)(C)	5EF6Z(K)(C)
8. Fail-safe with monitoring					58E(K)(C) 58F(K)(C)	5U8X(K)(C) 5U8Y(K)(C)	5E8Z(K)(C)	-	-	-

Electronic
Unique in the world
Developed with cutting-edge electronic components.
Ask our sales team for more information!



Coils

Electrical characteristics

	B	D	E	F	H	X	Y	Z
Electrical data	6-14V AC/DC	24V AC	12V DC	24V DC	9-16V AC/DC	9-24V AC/DC 12V DC	22-28V AC/DC 24V DC	6-28V AC/DC
Continuous duty	< 1 min	< 1 min	ED 100%	ED 100%	< 1 min	< 1 min / ED 100%	< 1 min / ED 100%	ED 100%
Transient Voltage Suppressor (TVS)	Si	Si	Si	Si	Si	Si	Si	Si
Rated resistance	8,5 Ω	42 Ω	42 Ω	200 Ω	14 Ω	43 Ω	200 Ω	6,5 Ω
Current consumption AC	0,50 A 6V 1 A 12V 1,16 A 14V	0,4 A	-	-	0,45 A 9V 0,61 A 12V 0,81 A 16V	0,15 A 9V 0,2 A 12V 0,39 A 24V	0,08 A 22V 0,08 A 24V 0,10 A 28V	Initial: 0,18 A 6V 0,39 A 12V 0,24 A 24V Maintenance: 0,10 A 6V 0,21 A 12V 0,11 A 24V
Current consumption DC (stabilized)	0,71 A 6V 1,41 A 12V 1,65 A 14V	-	0,29 A	0,12 A	0,64 A 9V 0,86 A 12V 1,14 A 16V	0,21 A 9V 0,28 A 12V 0,56 A 24V	0,11 A 22V 0,12 A 24V 0,14 A 28V	Initial: 0,16 A 6V 0,34 A 12V 0,17 A 24V Maintenance: 0,09 A 6V 0,14 A 12V 0,07 A 24V
Maximum side-load on AC	12V - 120 N	120 N	-	-	12V - 120 N	24 V - 200 N	28 V - 200 N	6 - 28V - 400 N
Maximum side-load on DC (stabilized)	12V - 10 N	-	10 N	10 N	12V - 10 N	12V - 50 N 12V 100% ED	24V - 50 N 24V 100% ED	6 - 28V - 400 N
Compatible coils for:	5 and 5F	5 and 5F	5 and 5F	5 and 5F	5 and 5F	5U and 5UF	5U and 5UF	5E and 5EF

Item numbers

Remember to replace the (K) and (C) with a number.

Ex.: 5U0X(K)(C) would be 5U0X21 if we choose Keeper 2 and Cover 1.

Keeper (K)

1		Adjustable keeper made of zamak for models: 5 / 5U / 5E Suitable for features: 0 / 1 / 4 / 6 / 8 X= 5,2 mm Y= 7,1 to 9,1 mm
		Adjustable keeper made of zamak for models: 5 / 5U / 5E Suitable for features: 2 / 3 X= 5,2 mm Y= 7,1 to 9,1 mm
2		Adjustable keeper made of zamak for models: 5 / 5U / 5E Suitable for features: 0 / 1 / 4 / 6 / 8 X= 5,2 mm Y= 7,1 to 9,1 mm
1		Adjustable keeper made of steel for models: 5F / 5UF / 5EF Suitable for features: 0 / 6 X= 6 mm Y= 7,1 to 10,1 mm
2		Adjustable keeper made of steel for models: 5F / 5UF / 5EF Suitable for features: 0 / 6 X= 6 mm Y= 7,1 to 10,1 mm
3		Adjustable keeper made of zamak for models: 5 / 5U / 5E Suitable for features: 0 / 1 / 4 / 6 / 8 X= 4,2 mm Y= 8,1 to 10,1 mm
4		Adjustable keeper made of zamak for models: 5 / 5U / 5E Suitable for features: 0 / 1 / 4 / 6 / 8 X= 4,2 mm Y= 8,1 to 10,1 mm
5		Adjustable keeper made of zamak for models: 5 / 5U / 5E Suitable for features: 0 / 1 / 4 / 6 / 8 X= 5,7 mm Y= 5,6 to 7,6 mm

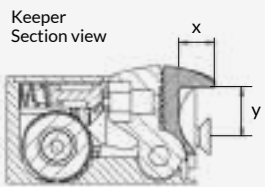

Dimension X
Keeper depth
Dimension Y
Keeper's adjustability from min. to max.

Cover (C)

0 Standard Inox	¡NEW COVER! Latch guide Designed for installations in the center of the door frame or to avoid cutting the frame. Compatible with keeper's 2 and 7	<p>The latch guide cover allows the door latch to neatly slide into position without blocking the door. Common problem: when the door is about to be opened, the door latch gets stuck between the electric strike and the doorframe. O&C solution: Thanks to the latch guide cover, the door latch can't get stuck in the cavity. The latch will thus smoothly slide into position and unlock the door.</p>
1 Latch guide		

SERIES 7 WATERPROOF!

Enjoying the outdoors

Sometimes electric strikes are subjected to sudden weather changes which may affect their internal mechanism.

In order to isolate this internal mechanism we have developed an external keeper for the box and an independent electrical connection, resulting in a waterproof electric strike able to withstand heavy rain.

IP54*

*IP54 protection against dust and pulverized water on an average of 10 liters per minute and pressure of 80-100kN/m².

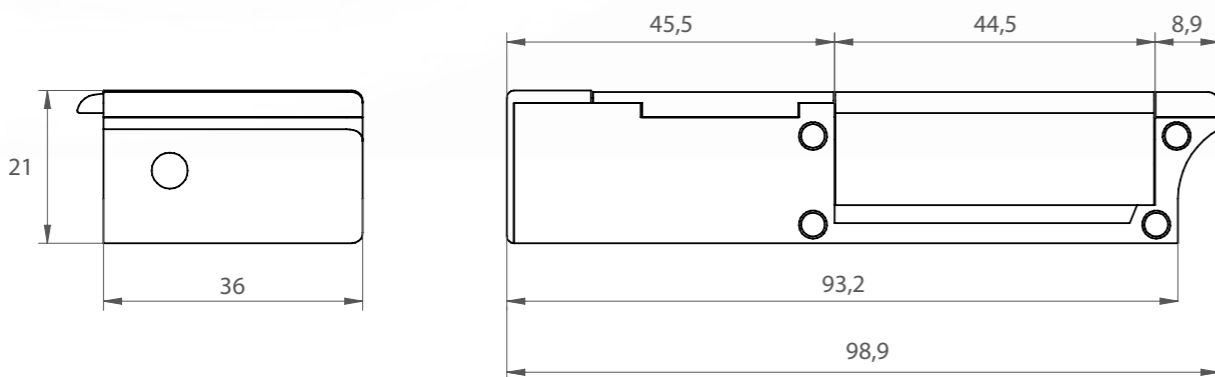

Technical characteristics

Break-in resistance (keeper's pressure)	3.500 N
Endurance rating <input type="checkbox"/> (cycles with no side-load)	200.000
Endurance rating <input checked="" type="checkbox"/> (cycles with 120 N side-load AC)	100.000
Temperature	- 25 °C to + 70 °C
Complies with the directive:	2014/30/UE 2011/65/UE

According to EN 14846 standard

Fail-secure:	3W100L000
Fail-safe:	3C100L000
Fail-secure with micro:	3W100L010
Fail-safe with micro:	3C100L010



WATER TIGHTNESS TEST
We have isolated the inside of the mechanism to prevent corrosion. The electric strike has been certified with the IP54 protection against dust and water.



MAGNETIC MICROSWITCH
A hidden magnetic sensor allows us to know the status of the door and keep water and dust away from the internal mechanism.



GOOD FOR MULTIPoint BOLT LOCKS
The design of the mechanism box is curved so the end matches the first bolt lock.

NEW ITEM NUMBERS (EXAMPLE)

Model	Function	Coil	Keeper	Cover
7R	0	L	4	0

ITEM NUMBERS AND FEATURES

Functions

7 DIN R

7 DIN L

0. Fail-secure



7R0D40
7R0L40
7R0M40
7R0N40
7R0P40

7L0D40
7L0L40
7L0M40
7L0N40
7L0P40



Important
Install the electric strike so that the coil is positioned at the top.

4. Fail-safe



7R4M40
7R4N40
7R4P40

7L4M40
7L4N40
7L4P40

6. Fail-secure with monitoring



7R6D40
7R6L40
7R6M40
7R6N40
7R6P40

7L6D40
7L6L40
7L6M40
7L6N40
7L6P40

8. Fail-safe with monitoring



7R8M40
7R8N40
7R8P40

7L8M40
7L8N40
7L8P40

A. Internal hold-open



7RAD40
7RAL40
7RAP40

7LAD40
7LAL40
7LAP40

Coils

Electrical characteristics

	D	L	M	N	P
Electrical data	24V AC	8-14V AC/DC	12V DC	24V DC	12V DC
Continuous duty	< 1 min	< 1 min	ED 100%	ED 100%	ED 100%
Transient Voltage Suppressor (TVS)	-	-	Si	Si	Si
Rated resistance	70 Ω	20 Ω	70 Ω	240 Ω	54 Ω
Current consumption AC	0,24 A	0,28 A 8V 0,42 A 12V 0,49 A 14V	-	-	-
Current consumption DC (stabilized)	-	0,4 A 8V 0,6 A 12V 0,7 A 14V	0,17 A	0,1 A	0,22 A
Maximum side-load on AC	120 N	12V - 120 N	-	-	-
Maximum side-load on DC (stabilized)	-	12V - 10 N	10 N	10 N	10 N

Our special Keepers and Covers ensures the best fitting possible

Keeper section view



Dimension X
Keeper depth

Dimension Y
Keeper's adjustability
from minimum
to maximum

Section view

Keeper

4



Fixed keeper
made of zamak
X= 8,8 mm
Y= 12,8 mm

Cover

0 Nylon



Reed

The Reed is a sensor that detects and monitors the door's position. The microswitch activates magnetically, thus avoiding the need to perforate the box. Watertightness assured!

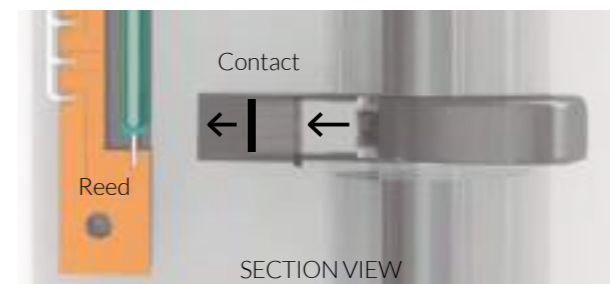

CHARACTERISTICS

- Maximum switching voltage: 100 V DC
- Maximum switching current: 300 mA DC
- Maximum power load: 3 W

SERIES 9

ARMOURED

High security at your fingertips

An electric strike developed for armoured doors with multipoint bolt locks. We want to ease accessibility of heavy doors with robust locks.

Technical characteristics

Break-in resistance (keeper's pressure)	4.000 N
Endurance rating <input type="checkbox"/> (cycles with no side-load)	200.000
Endurance rating <input checked="" type="checkbox"/> (cycles with 120 N side-load AC)	200.000
Temperature	- 25 °C to + 70 °C
Complies with the directive:	2014/30/UE 2011/65/UE

According to EN 14846 standard

Fail-secure: 3 X 3 0 0 L 0 0 0

Fail-safe: 3 C 3 0 0 L 0 0 0

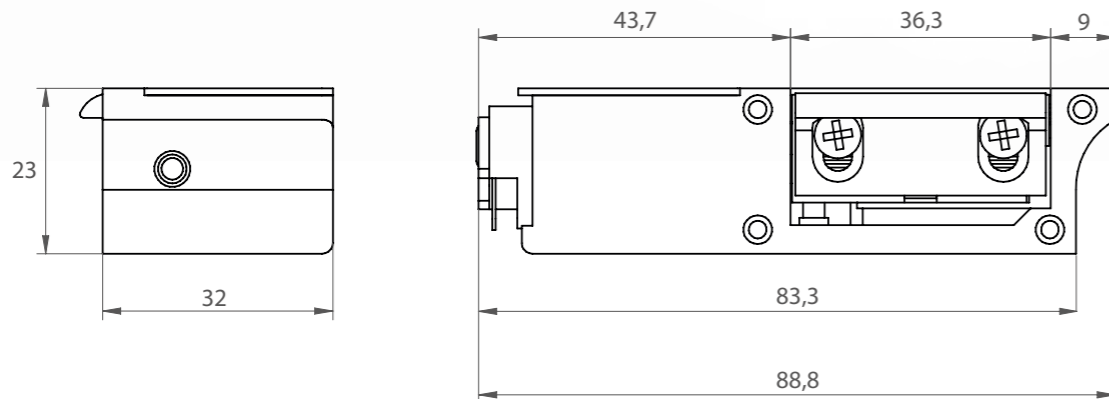

COMPACT AND SMALL
The latch's size has been reduced to make it more adaptable and for the fastener to gain more resistance.



INFALLIBLE
The new design of the hold-open system ensures that the door latch is always in contact with it, even if the keeper moves to adjust to the door.

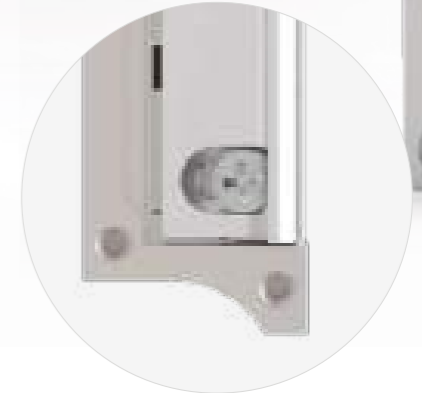

DESIGNED FOR MULTIPOINT LOCKS
The end of the box is curved so the separation between lock and the first bolt is only 5 mm.

NEW ITEM NUMBERS (EXAMPLE)

Model	Function	Coil	Keeper	Cover
9R	0	L	(K)	0

ITEM NUMBERS AND FEATURES

Functions

	9 DIN R	9 DIN L
0. Fail-secure	 <p>9R0D(K)0 9R0L(K)0 9R0M(K)0 9R0N(K)0 9R0P(K)0</p>	 <p>9L0D(K)0 9L0L(K)0 9L0M(K)0 9L0N(K)0 9L0P(K)0</p>
2. Hold-open	 <p>9R2D(K)0 9R2L(K)0 9R2M(K)0 9R2N(K)0 9R2P(K)0</p>	 <p>9L2D(K)0 9L2L(K)0 9L2M(K)0 9L2N(K)0 9L2P(K)0</p>
3. Hold-open with mechanical unlocking	 <p>9R3D(K)0 9R3L(K)0 9R3M(K)0 9R3N(K)0 9R3P(K)0</p>	 <p>9L3D(K)0 9L3L(K)0 9L3M(K)0 9L3N(K)0 9L3P(K)0</p>
4. Fail-safe	 <p>9R4M(K)0 9R4N(K)0 9R4P(K)0</p>	 <p>9L4M(K)0 9L4N(K)0 9L4P(K)0</p>
A. Internal hold-open	 <p>9RAD(K)0 9RAL(K)0 9RAP(K)0</p>	 <p>9LAD(K)0 9LAL(K)0 9LAP(K)0</p>
B. Internal hold-open with mechanical unlocking	 <p>9RBD(K)0 9RBL(K)0 9RBP(K)0</p>	 <p>9LBD(K)0 9LBL(K)0 9LBP(K)0</p>



Important
Install the electric strike so that the coil is positioned at the top.

Coils

Electrical characteristics

	D	L	M	N	P
Electrical data	24V AC	8-14V AC/DC	12V DC	24V DC	12V DC
Continuous duty	< 1 min	< 1 min	ED 100%	ED 100%	ED 100%
Transient Voltage Suppressor (TVS)	-	-	Si	Si	Si
Rated resistance	70 Ω	20 Ω	70 Ω	240 Ω	54 Ω
Current consumption AC	0,24 A	0,28 A 8V 0,42 A 12V 0,49 A 14V	-	-	-
Current consumption DC (stabilized)	-	0,4 A 8V 0,6 A 12V 0,7 A 14V	0,17 A	0,1 A	0,22 A
Maximum side-load on AC	120 N	12V - 120 N	-	-	-
Maximum side-load on DC (stabilized)	-	12V - 10 N	10 N	10 N	10 N

Creating new item numbers



Remember to replace the (K) that correspond to the Keeper of the product by the desired number. For example:
9ROL(K)0 would be **9ROL20** if we chose Keeper 2.

Keeper section view



Dimension X
Keeper depth
Dimension Y
Keeper's adjustability from minimum to maximum
Section view

Keeper (K)

1		Adjustable keeper made of zamak. Suitable for all functions. Features 2 / 3 manufactured with a hole. X= 6 mm
2		Adjustable keeper made of zamak. Suitable for all functions. Features 2 / 3 manufactured with a hole. X= 9,3 mm

Cover



SERIES 25

SMALL AND INCREDIBLE!

100% Reversible

Entirely made of special steel alloy increases the resistance of the electric strike to 8.000 N.

A symmetric construction with radial adjustable keeper and electronic protection that provide versatility to your installation.



25

Maximum resistance

Ideal for heavy and high-security doors!

A larger span of the electric strike ensures instant blocking of heavier doors. The huge selection of voltages allows a quickly aperture with only one function of the energy consume. The series 25 has the highest side-load of all models.



Technical characteristics

Break-in resistance (keeper's pressure)	8.000 N
Dynamic strength (door impact)	4.450 N
Endurance rating <input type="checkbox"/> (cycles with no side-load)	200.000
Temperature	- 25 °C to + 70 °C
Complies with the directive: 2014/30/UE and 2011/65/UE	

Technical characteristics 25

Endurance rating <input checked="" type="checkbox"/> (cycles with 120 N side-load on AC)	200.000
Complies with EN14846:	
Fail-secure:	<input type="checkbox"/> 3 X 3 0 0 L 0 0 0
Fail-safe:	<input type="checkbox"/> 3 C 3 0 0 L 0 0 0
Fail-secure with micro:	<input type="checkbox"/> 3 X 3 0 0 L 0 1 0
Fail-safe with micro:	<input type="checkbox"/> 3 C 3 0 0 L 0 1 0

Technical characteristics 25E

Endurance rating <input checked="" type="checkbox"/> (cycles with 250 N side-load on AC/DC)	200.000
Complies with EN14846:	
Fail-secure:	<input type="checkbox"/> 3 Y 3 0 0 L 0 0 0
Fail-safe:	<input type="checkbox"/> 3 C 3 0 0 L 0 0 0
Fail-secure with micro:	<input type="checkbox"/> 3 Y 3 0 0 L 0 1 0
Fail-safe with micro:	<input type="checkbox"/> 3 C 3 0 0 L 0 1 0

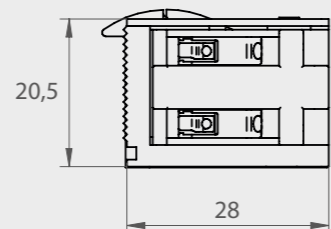

CURVES ARE BEAUTIFUL
The radial keeper turns inside the mechanisms box, which means you won't need to cut the doorframe.



DEEP AND ADJUSTABLE
For a better adjustment, the depth has been increased up to 6 mm for the adjustable keeper, with a displacement of 3 mm for an accurate adjustment for the door.



AUTOMATIC SYSTEM
The joint of the keeper and the automatic switch removes the critical spaces and offers a better contact with the latch of the door.

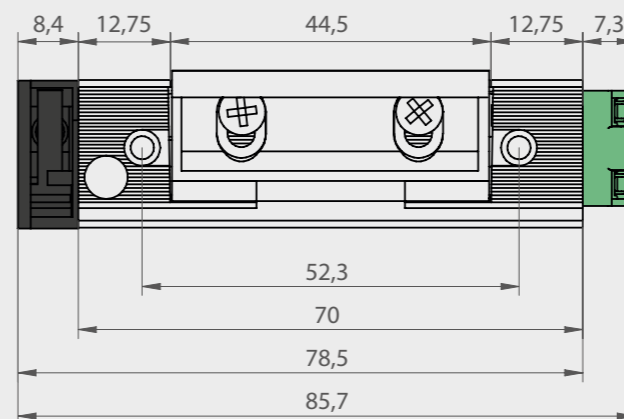

25E

Smart management

Electronics makes us universal

An electronic microchip is responsible for automatically managing any voltage from 6 - 28 V AC/DC 100%. It also incorporates a temperature detection system to prevent the mechanism from overheating reaching maximum temperatures of 40°C. The internal programming achieves a greater capacity of lateral preload increasing it up to 400 N.

UP TO
400 N
SIDE - LOAD
AC - DC

ELECTRONIC
MICROCHIP

6-28 V
AC / DC
100%



NEW ITEM NUMBERS (EXAMPLE)

Model	Function	Coil	Keeper	Cover
25E	0	Z	1	0

ITEM NUMBERS AND FEATURES

Functions

25

25E

0. Fail-secure



250B10
250D10
250E10
250F10
250H10
250S10



25E0Z10

2. Hold-open



252B10
252D10
252E10
252F10
252H10
252S10



25E2Z10

4. Fail-safe



254E10
254F10



25E4Z10

6. Fail-secure with monitoring



256B10
256D10
256E10
256F10
256H10
256S10



25E6Z10

8. Fail-safe with monitoring



258E10
258F10



25E8Z10

Coils

Electrical characteristics

	B	D	E	F	H	S	Z
Electrical data	6-14V AC/DC	24V AC	12V DC	24V DC	8-14V AC/DC	8V DC	6-28V AC/DC
Continuous duty	< 1 min	< 1 min	ED 100%	ED 100%	< 1 min	ED 100%	ED 100%
Transient Voltage Suppressor (TVS)	-	-	Si	Si	-	Si	Si
Rated resistance	8,5 Ω	50 Ω	50 Ω	185 Ω	14 Ω	25 Ω	6,5 Ω
Current consumption AC	0,5 A 6V 1 A 12V 1,16 A 14V	0,34 A	-	-	0,4 A 8V 0,61 A 12V 0,71 A 14V	-	Initial: 0,18 A .. 6V 0,39 A .. 12V 0,24 A .. 24V Maintenance: 0,10 A .. 6V 0,21 A .. 12V 0,11 A .. 24V
Current consumption DC (stabilized)	0,71 A 6V 1,4 A 12V 1,65 A 14V	-	0,24 A	0,13 A	0,57 A 8V 0,86 A 12V 1 A 14V	0,32 A	Initial: 0,16 A .. 6V 0,34 A .. 12V 0,17 A .. 24V Maintenance: 0,09 A .. 6V 0,14 A .. 12V 0,07 A .. 24V
Maximum side-load on AC	12V - 200 N	120 N	-	-	120 N	-	6 - 28V - 400 N
Maximum side-load on DC (stabilized)	12V - 10 N	-	10 N	10 N	10 N	10 N	6 - 28V - 400 N
Compatible coils for:	25	25	25	25	25	25	25E

Our special Keepers and Covers ensures the best fitting possible

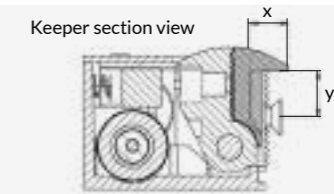

Dimension X
Keeper depth

Dimension Y
Keeper's adjustability from minimum to maximum

Section view

Keeper



Cover





OPENERS
& CLOSERS

OPENERS
& CLOSERS

OPENERS
& CLOSERS

OPENERS
& CLOSERS

FACEPLATES

Faceplates fasten, embellish, protect electric doors and strikes.

Our selection of faceplates adds a touch of design, allowing you to choose from a wide range of shapes and colors.

FACEPLATES



PERSONALIZE

We can create different shapes or hole positions to **personalize your ideal faceplate**. Contact us and we will advise you to choose the one that best suits your needs.

LASER

We can **laser print your logo** on the faceplate. For this option add the **letter L** after the color category. If you wish the logo to be on both sides add the **letter R**.

Easy coding!

Model	Color						Laser print		
	Usual colors					Special colors (choose RAL)	No laser print	One side	Two side. Reversible
	Brown	Inox	Grey	Black	White				
	B	X	Z	K	W	S	-	L	R

Additional given information

DIN 107	Recommended series

Category	Model	B	X	Z	K	W	S	-	L	R	DIN 107	Recommended series
BOX FACEPLATE	B09	B	X	Z	K	W	S	-	-	-	DIN R	2S 3 4 5 7 9 25
	B10	B	X	Z	K	W	S	-	-	-	DIN L	2S 3 4 5 7 9 25
	B11	B	X	Z	K	W	S	-	-	-	DIN R	2S 3 4 5 7 9 25
	B12	B	X	Z	K	W	S	-	-	-	DIN L	2S 3 4 5 7 9 25
	B81	B	X	Z	K	W	S	-	L	R	REVERSIBLE	2 3 4 5 7 9 25
	B84	B	X	Z	K	W	S	-	L	R	REVERSIBLE	2 3 4 5 7 9 25
	B86	B	X	G	K	W	S	-	L	R	REVERSIBLE	2 3 4A 5 7 9 25
	B87	B	X	G	K	W	S	-	L	R	REVERSIBLE	2 3 4A 5 7 9 25
SHORT FACEPLATE	S01	B	X	Z	K	W	S	-	L	R	REVERSIBLE	2 3 4 5 7 9 25
	S02	B	X	Z	K	W	S	-	L	R	REVERSIBLE	2 3 4 5 7 9 25
	S27	B	X	Z	K	W	S	-	L	R	REVERSIBLE	2 3 4 5 7 9 25
	S28	B	X	Z	K	W	S	-	L	R	REVERSIBLE	2 3 4 5 7 9 25
	S66	B	X	Z	K	W	S	-	L	R	REVERSIBLE	2 3 4 5 7 9 25
	S76	B	X	Z	K	W	S	-	L	R	REVERSIBLE	2 3 4 5 7 9 25
	S80	B	X	Z	K	W	S	-	L	R	REVERSIBLE	2 3 4 5 7 9 25
	S92	B	X	Z	K	W	S	-	L	R	REVERSIBLE	2 3 4 5 7 9 25
	S94	B	X	Z	K	W	S	-	L	R	REVERSIBLE	2 3 4 5 7 9 25
	S95	B	X	Z	K	W	S	-	L	R	REVERSIBLE	2 3 4 5 7 9 25
	S96	B	X	Z	K	W	S	-	L	R	REVERSIBLE	2 3 4 5 7 9 25
	ANGLED FACEPLATE	A08	B	X	Z	K	W	S	-	L	-	DIN R
A09		B	X	Z	K	W	S	-	L	-	DIN L	2 3 4 5 7 9 25
A10		B	X	Z	K	W	S	-	L	-	DIN R	2 3 4 5 7 9 25
A11		B	X	Z	K	W	S	-	L	-	DIN L	2 3 4 5 7 9 25
A12		B	X	Z	K	W	S	-	L	-	DIN R	2 3 4 5 7 9 25
A13		B	X	Z	K	W	S	-	L	-	DIN L	2 3 4 5 7 9 25
A14		B	X	Z	K	W	S	-	L	-	DIN R	2 3 4 5 7 9 25
A15		B	X	Z	K	W	S	-	L	-	DIN L	2 3 4 5 7 9 25
A16		B	X	Z	K	W	S	-	L	R	REVERSIBLE	2 3 4 5 7 9 25
A17		B	X	Z	K	W	S	-	L	R	REVERSIBLE	2 3 4 5 7 9 25
A24		B	X	Z	K	W	S	-	L	-	DIN R	2 3 4 5 7 9 25
A25		B	X	Z	K	W	S	-	L	-	DIN L	2 3 4 5 7 9 25
A44		B	X	Z	K	W	S	-	L	-	DIN R	2 3 4 5 7 9 25
A45		B	X	Z	K	W	S	-	L	-	DIN R	2 3 4 5 7 9 25
A47		B	X	Z	K	W	S	-	L	-	DIN L	2 3 4 5 7 9 25
A48		B	X	Z	K	W	S	-	L	-	DIN L	2 3 4 5 7 9 25
A49		B	X	Z	K	W	S	-	L	-	DIN L	2 3 4 5 7 9 25
A50		B	X	Z	K	W	S	-	L	-	DIN R	2 3 4 5 7 9 25
LONG FACEPLATE	L03	B	X	Z	K	W	S	-	L	R	REVERSIBLE	2 3 4 5 7 9 25
	LC3	B	X	Z	K	W	S	-	L	R	REVERSIBLE	2 3 4 5 7 9 25
	LD3	B	X	Z	K	W	S	-	L	R	REVERSIBLE	2 3 4 5 7 9 25
	L04	B	X	Z	K	W	S	-	L	R	REVERSIBLE	2 3 4 5 7 9 25
	LC4	B	X	Z	K	W	S	-	L	R	REVERSIBLE	2 3 4 5 7 9 25
	LD4	B	X	Z	K	W	S	-	L	R	REVERSIBLE	2 3 4 5 7 9 25
	L05	B	X	Z	K	W	S	-	L	R	REVERSIBLE	2 3 4 5 7 9 25
	LC5	B	X	Z	K	W	S	-	L	R	REVERSIBLE	2 3 4 5 7 9 25
	LD5	B	X	Z	K	W	S	-	L	R	REVERSIBLE	2 3 4 5 7 9 25
	L20	B	X	Z	K	W	S	-	L	-	DIN R	2 3 4 5 7 9 25
	L21	B	X	Z	K	W	S	-	L	-	DIN L	2 3 4 5 7 9 25
	L22	B	X	Z	K	W	S	-	L	-	DIN R	2 3 4 5 7 9 25
	L23	B	X	Z	K	W	S	-	L	-	DIN L	2 3 4 5 7 9 25
	L26	B	X	Z	K	W	S	-	L	R	REVERSIBLE	2 3 4 5 7 9 25
	L29	B	X	Z	K	W	S	-	L	R	REVERSIBLE	2 3 4 5 7 9 25
	L30	B	X	Z	K	W	S	-	L	R	REVERSIBLE	2 3 4 5 7 9 25
	L38	B	X	Z	K	W	S	-	L	R	REVERSIBLE	2 3 4 5 7 9 25
	L39	B	X	Z	K	W	S	-	L	R	REVERSIBLE	2 3 4 5 7 9 25
L43	B	X	Z	K	W	S	-	L	R	REVERSIBLE	2 3 4 5 7 9 25	
LC43	B	X	Z	K	W	S	-	L	R	REVERSIBLE	2 3 4 5 7 9 25	
LD43	B	X	Z	K	W	S	-	L	R	REVERSIBLE	2 3 4 5 7 9 25	
L60	B	X	Z	K	W	S	-	L	R	REVERSIBLE	2 3 4 5 7 9 25	
L67	B	X	Z	K	W	S	-	L	R	REVERSIBLE	2 3 4 5 7 9 25	
L68	B	X	Z	K	W	S	-	L	R	REVERSIBLE	2 3 4 5 7 9 25	
L69	B	X	Z	K	W	S	-	L	R	REVERSIBLE	2 3 4 5 7 9 25	
L70	B	X	Z	K	W	S	-	L	R	REVERSIBLE	2 3 4 5 7 9 25	
L71	B	X	Z	K	W	S	-	L	R	REVERSIBLE	2 3 4 5 7 9 25	
L72	B	X	Z	K	W	S	-	L	R	REVERSIBLE	2 3 4 5 7 9 25	
L73	B	X	Z	K	W	S	-	L	-	DIN R	2 3 4 5 7 9 25	
L74	B	X	Z	K	W	S	-	L	-	DIN L	2 3 4 5 7 9 25	
L75	B	X	Z	K	W	S	-	L	R	REVERSIBLE	2 3 4 5 7 9 25	
L79	B	X	Z	K	W	S	-	L	R	REVERSIBLE	2 3 4 5 7 9 25	
L94	B	X	Z	K	W	S	-	L	R	REVERSIBLE	2 3 4 5 7 9 25	
L95	B	X	Z	K	W	S	-	L	R	REVERSIBLE	2 3 4 5 7 9 25	
L96	B	X	Z	K	W	S	-	L	R	REVERSIBLE	2 3 4 5 7 9 25	

Standard holes

L03
L04
L05
L43



Centered holes

LC3
LC4
LC5
LC43

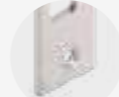

Diagonal holes

LD3
LD4
LD5
LD43

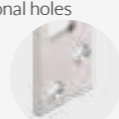

Reference example:
Model +
Color +
Laser (optional)

L03X
LC3ZL

BOX

SHORT

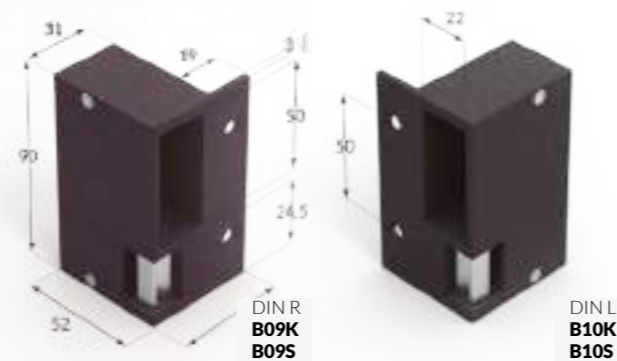

DIN R
B09K
B09S

DIN L
B10K
B10S



Rev.
S01B
S01X
S01Z
S01K
S01W
S01S



Rev.
S02B
S02X
S02Z
S02K
S02W
S02S

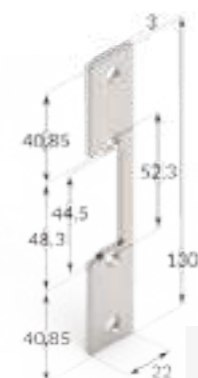

Rev.
S27X



Rev.
S28X

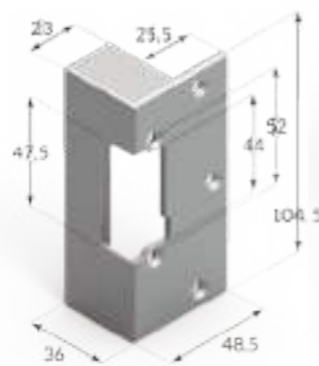

Rev.
B81B
B81Z
B81K
B81W
B81S

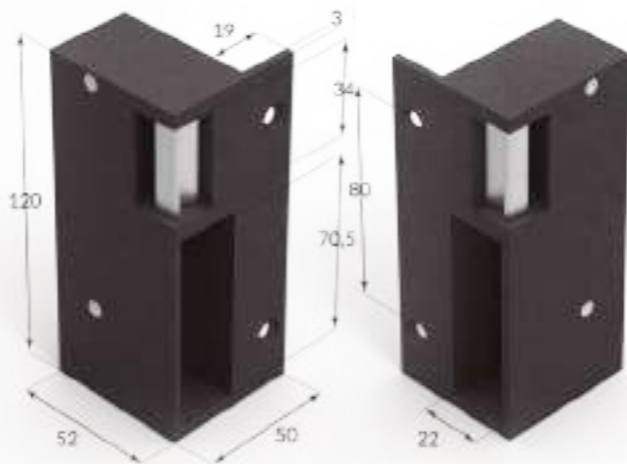

DIN R
B11K
B11S

DIN L
B12K
B12S

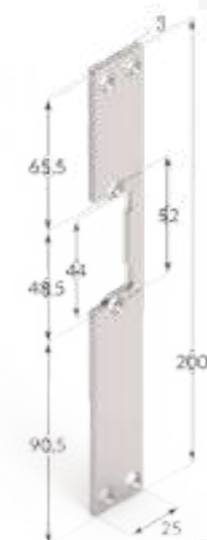

Rev.
S66X

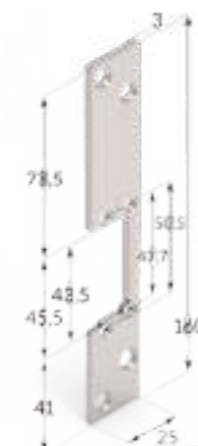

Rev.
S76X



Rev.
S80B
S80Z
S80K
S80W
S80S



Rev.
S92X

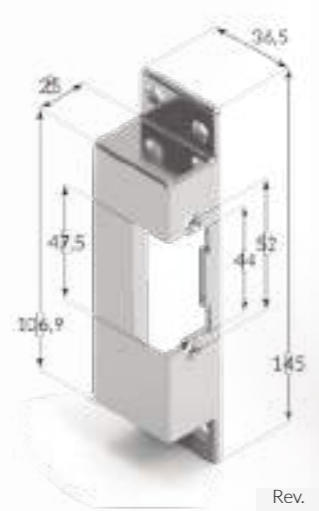

Rev.
B84B
B84Z
B84K
B84W
B84S

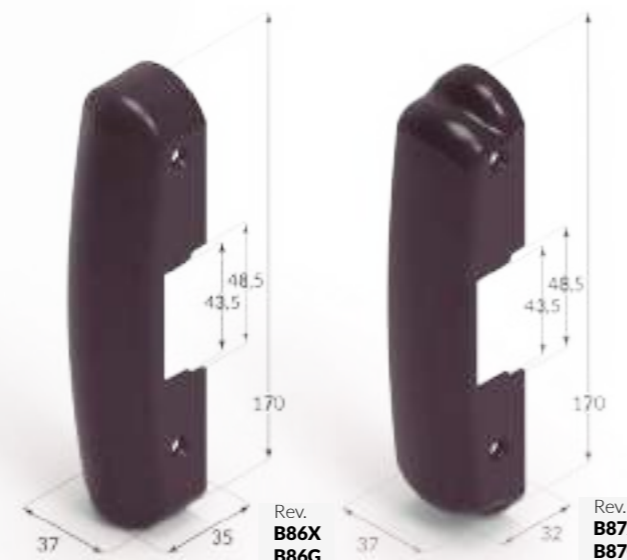

Rev.
B86X
B86G
B86K
B86W
B86S

Rev.
B87X
B87G
B87K
B87W
B87S

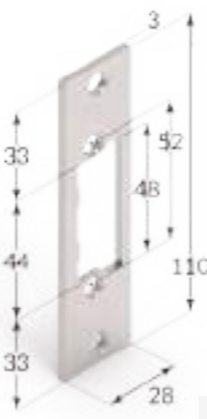

Rev.
S94X

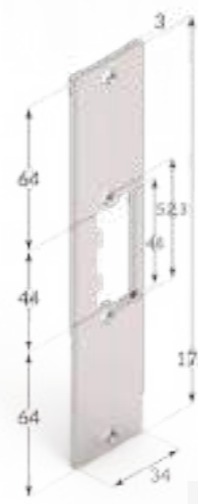

Rev.
S95X

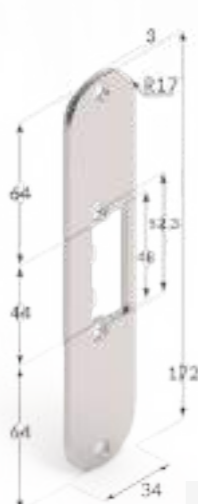

Rev.
S96X

B. Brown
X. Inox
Z. Grey
K. Black
W. White
S. Special color



FACEPLATES

BOX AND SHORT



ANGLED

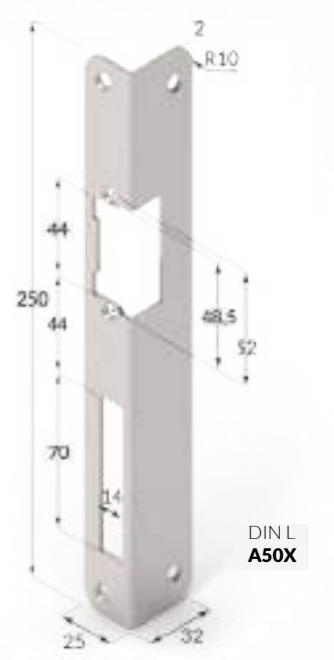
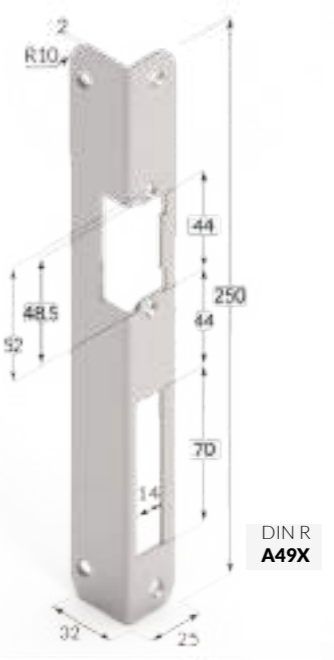
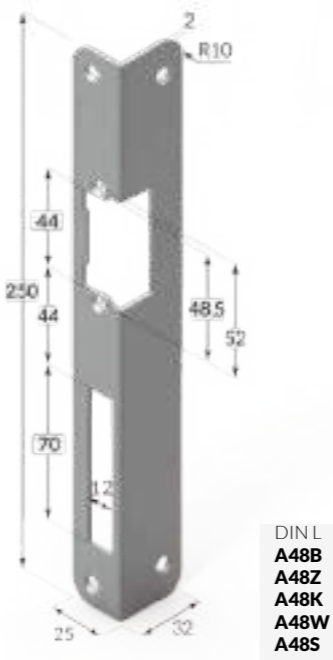
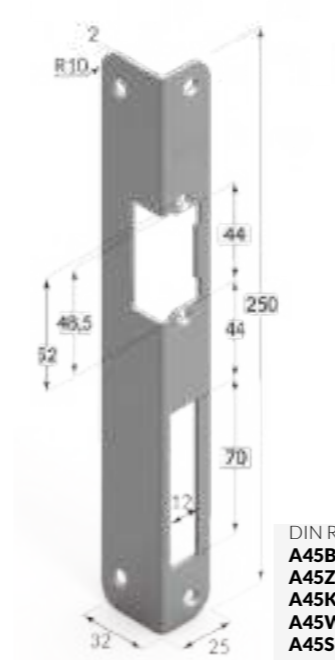
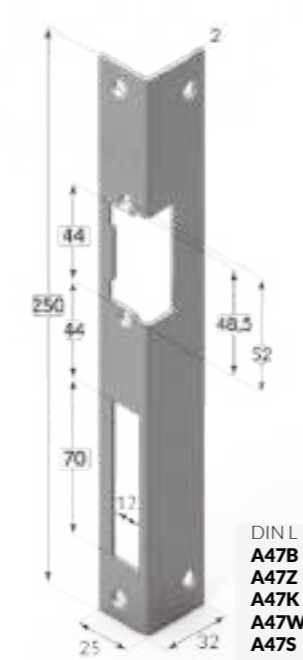
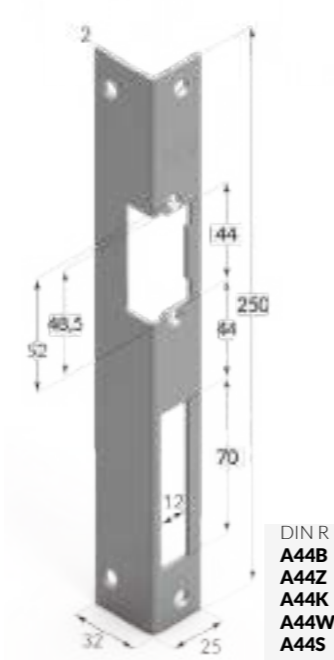
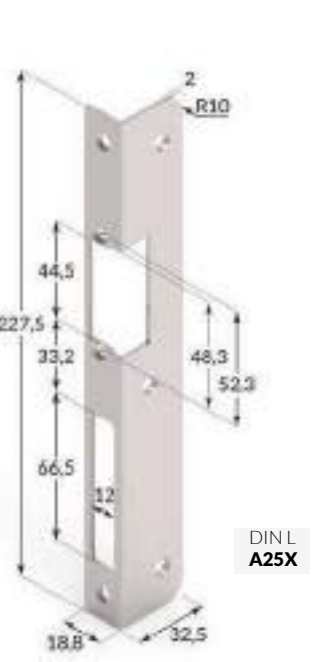
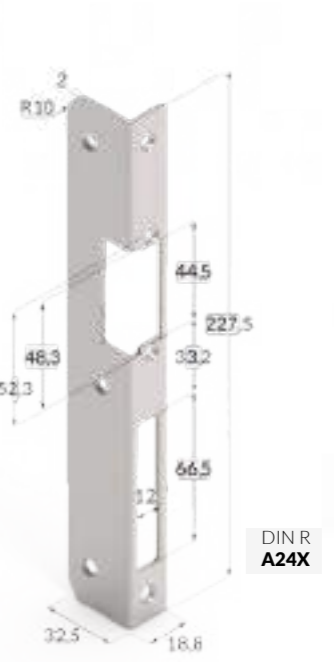
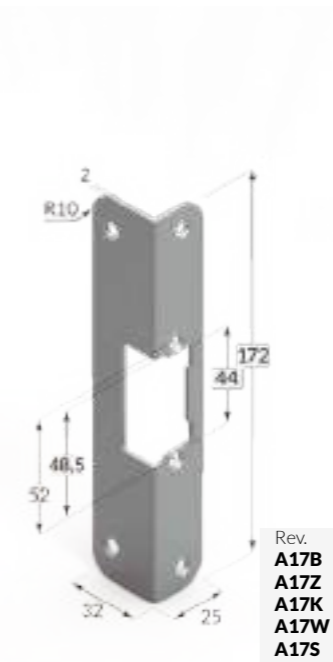
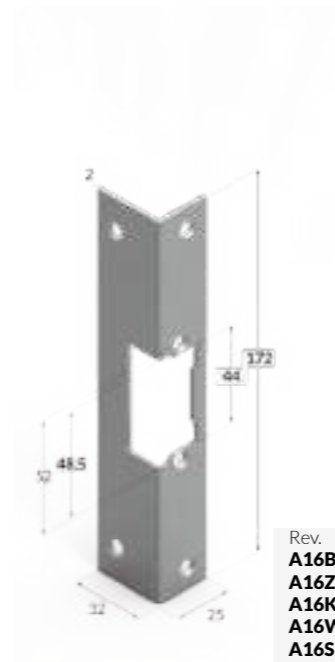
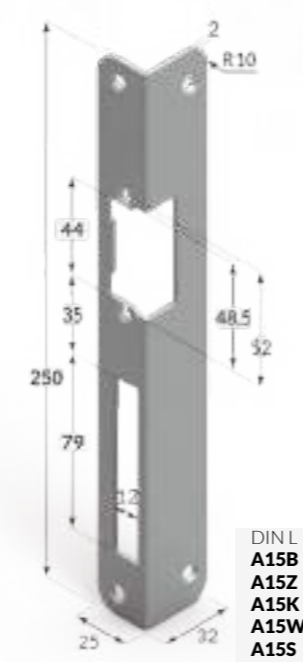
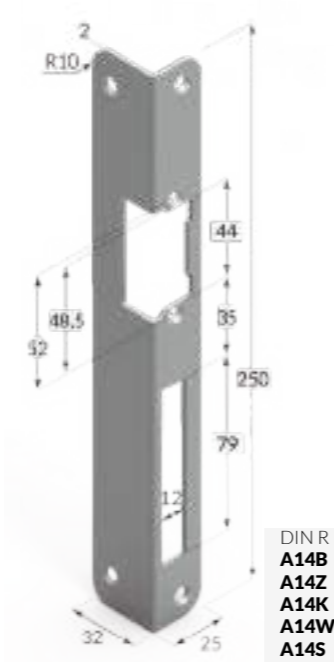
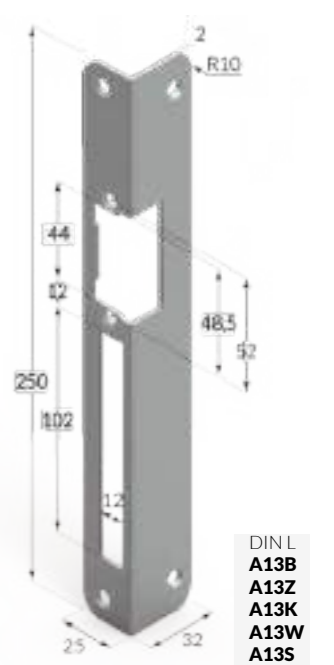
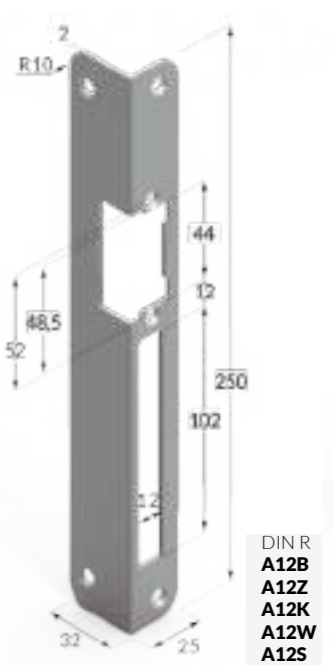
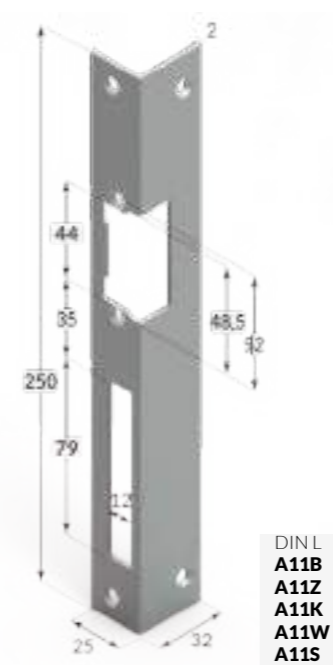
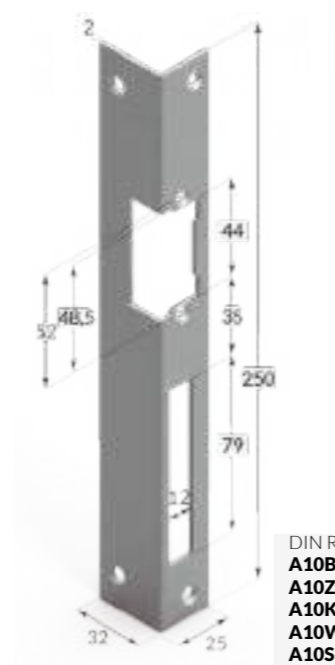
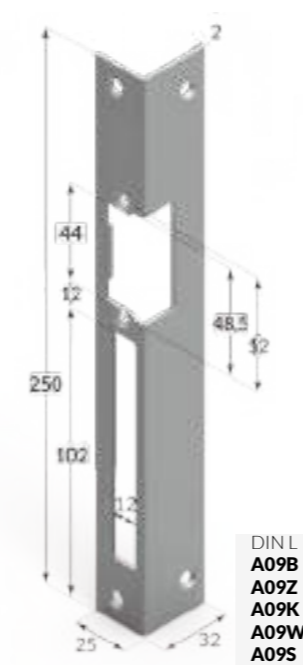
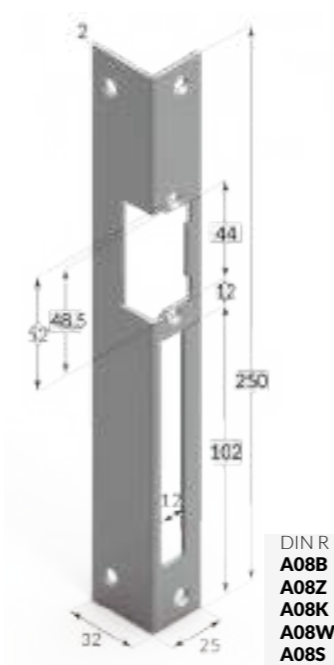

B. Brown
X. Inox
Z. Grey
K. Black
W. White
S. Special color

FACEPLATES
ANGLED

LONG

- B.** Brown
- X.** Inox
- Z.** Grey
- K.** Black
- W.** White
- S.** Special color

Standard

- L03**
- L04**
- L05**
- L43**

Centered

- LC3**
- LC4**
- LC5**
- LC43**

Diagonal

- LD3**
- LD4**
- LD5**
- LD43**

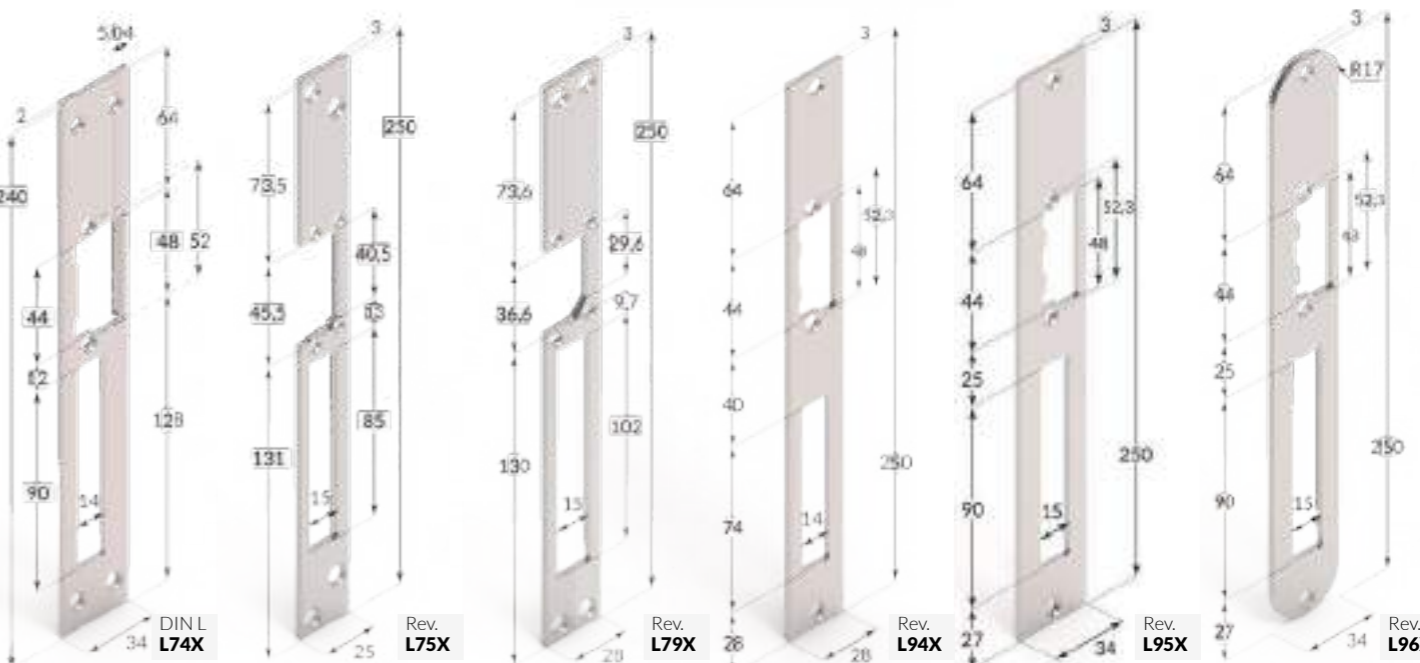
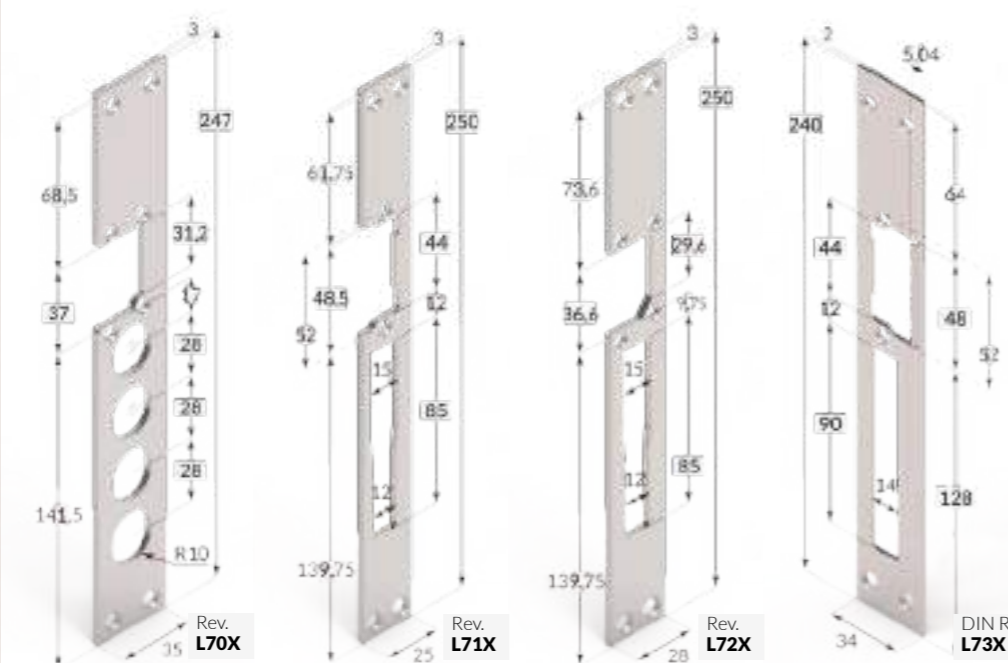
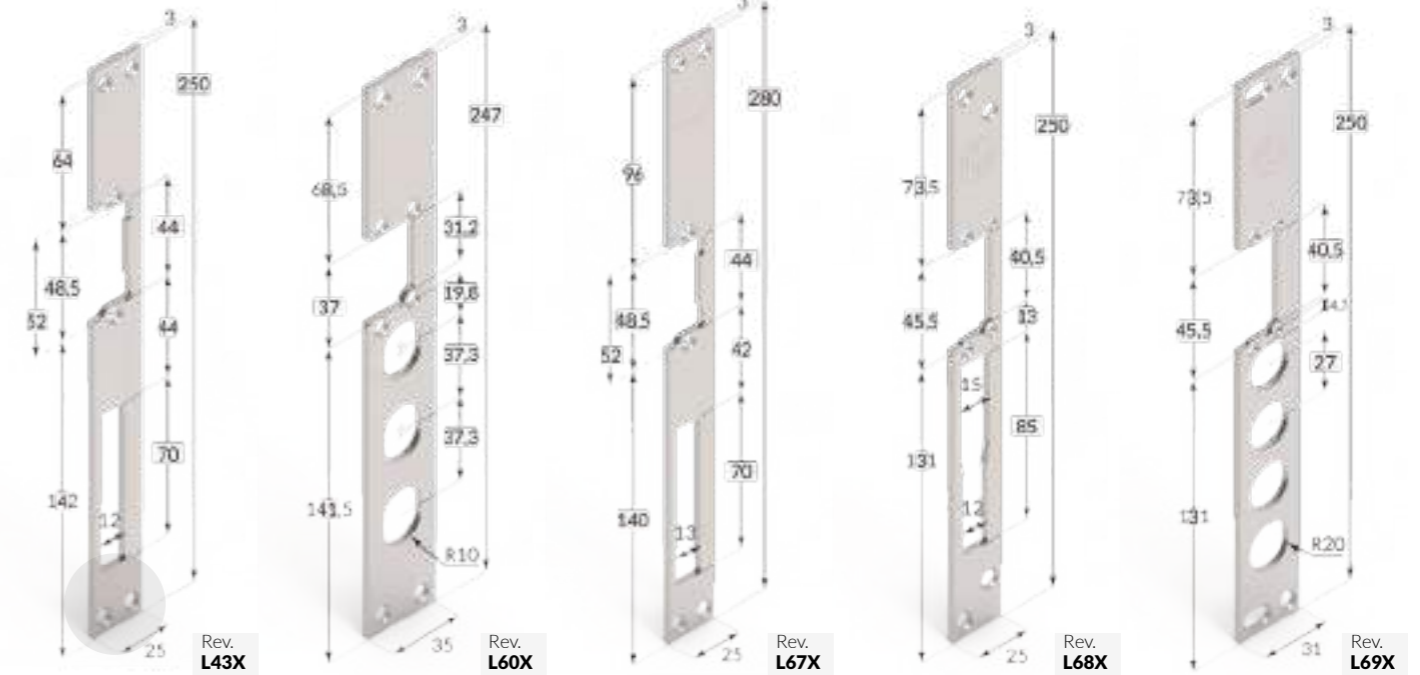
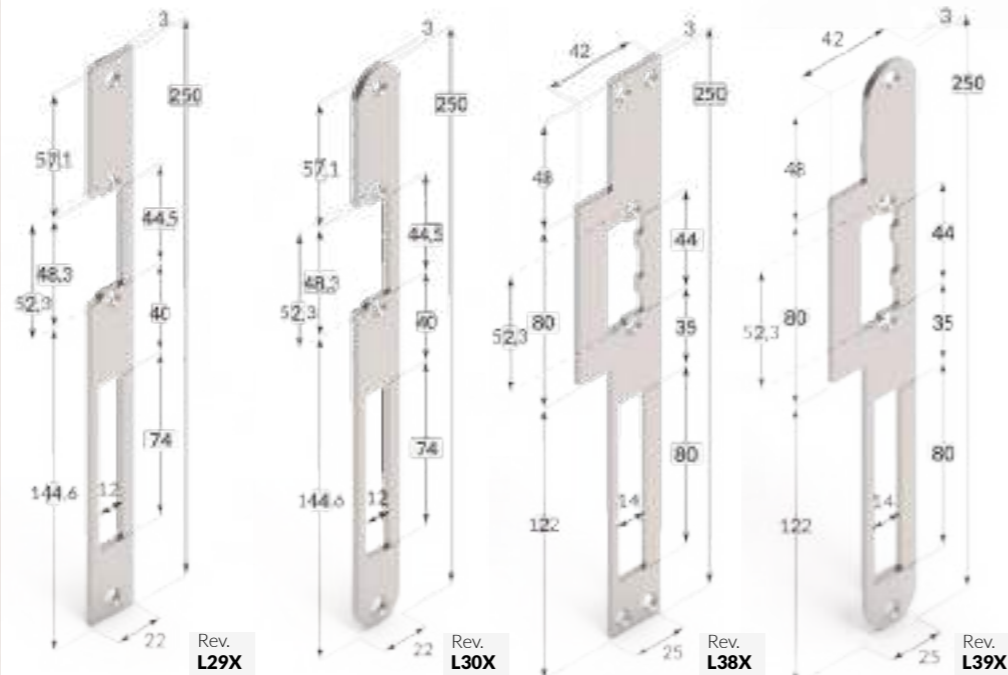
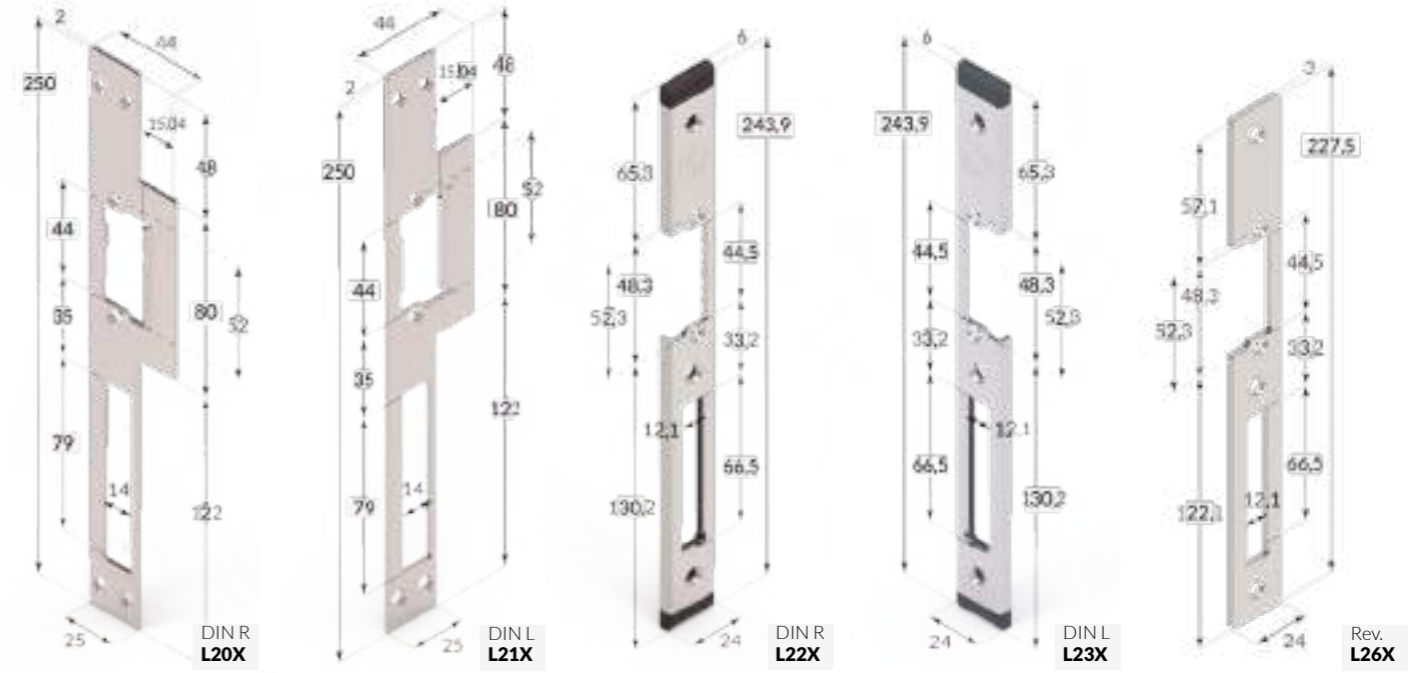
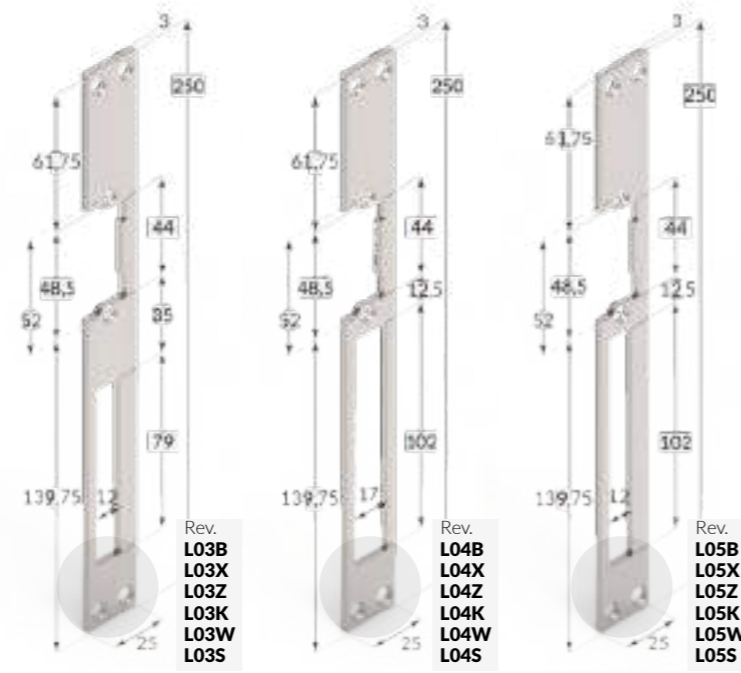

FACEPLATES
LONG

DUMMIES

Don't be a dummy, protect your installation

Mechanical electric strike

Dummies are often used during construction work for building safety. They are used to keep doors closed or grant easy access to areas that are under construction. This will avoid valuable electric strikes deterioration or theft of materials.

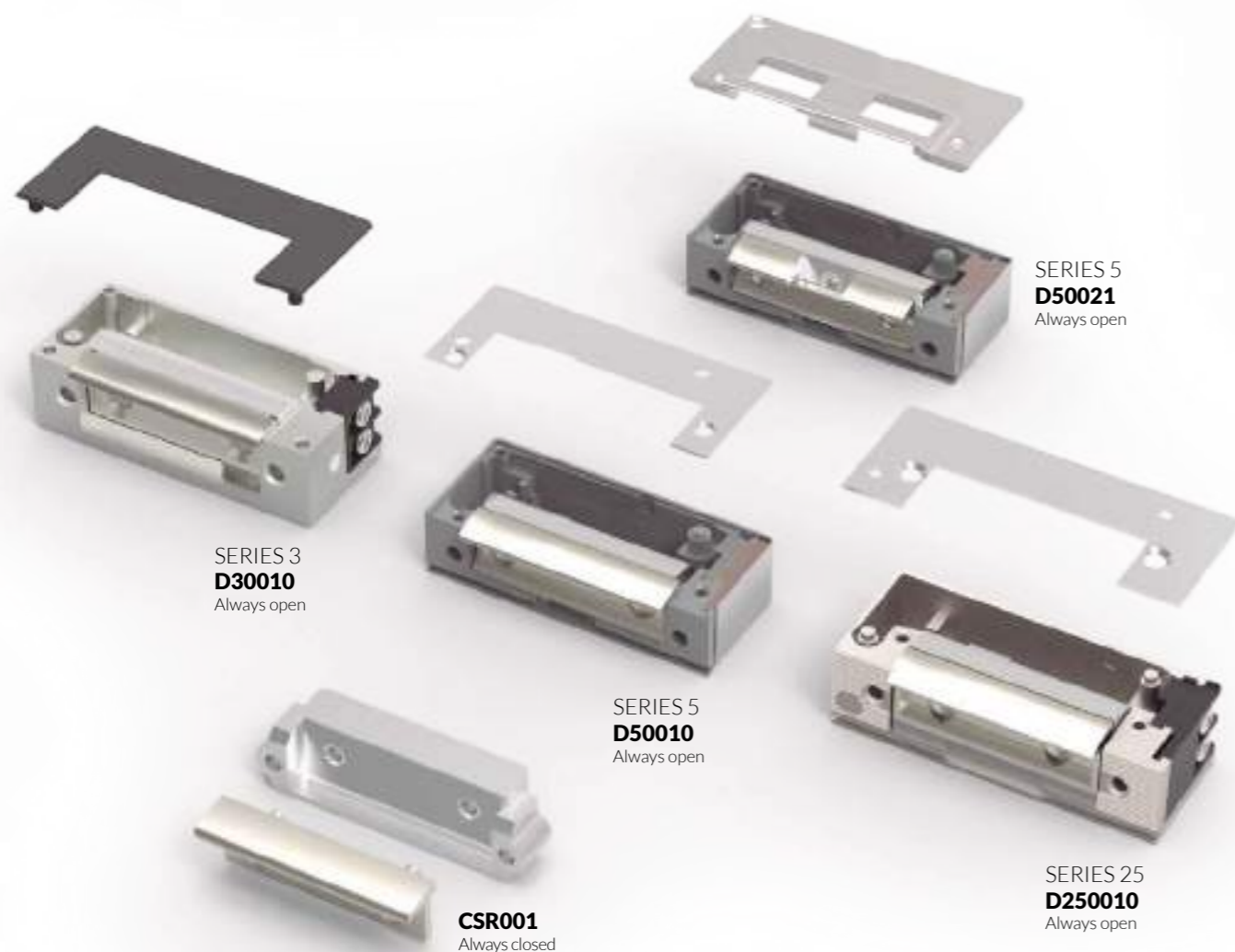

SERIES 3
D30010
Always open

SERIES 5
D50010
Always open

SERIES 5
D50021
Always open

SERIES 25
D250010
Always open

CSR001
Always closed

COMPLEMENTS

BLACK BOX

The importance of the details

Groove embellisher

A black box is an elegant solution to limit the holding place of the bolts. It goes installed behind the faceplate hiding the ugly insides of the door leaf from sight.



HS
Short box

HL
Long box



PERSONALIZE

We can customize the mechanical models by choosing the Keeper (K) and the Cover (C) that suits you best. Consult the page of the ITEM NUMBERS AND FEATURES of each series.

SERIES 3
D30010
D300(K)(C)

SERIES 5
D50010
D500(K)(C)

SERIES 25
D250010

ELECTROMAGNETIC LOCKS

Electromagnetic locks or maglocks consist of a powerful electromagnet mounted on the door frame and a counterplate mounted on the door. Once activated the electromagnet holds fast to the counterplate and the door remains closed. Two LED's informs at a glance whether the electromagnetic lock is open or closed.

Maglocks are popular among our customers for its effortless installation, durability and trustworthiness. At O&C we offer a vast range of maglocks in different sizes, voltages, mountings and holding forces to best suit your needs.

INSTALLATION OF AN ELECTROMAGNETIC LOCK

L



L installation

For doors that open outwards.

The counterplate is fixed directly on the door leaf and the electromagnet installed on the lintel. If the frame is too small we use an L-shaped bracket.

ME and MEX



Z installation

For doors that open inwards.

A Z-shaped bracket is used to attach the counterplate to the door leaf.

ME and MEX



Z

U



U installation

For glass doors

In order to prevent damage to your glass door the counterplate has to be installed using a U-shaped bracket which is fastened to the top of the door leaf.

ME and MEX



F installation

For fire doors

The counterplate is connected to a specific support for Ei doors. In this way, it is not necessary to completely perforate the door and lose its certification.

ME and MEX



F

S



S installation

For sliding doors

The electromagnet is imbedded into the side of the doorframe, while the counterplate goes fixed to the side of the door using a small and discrete U-shaped support.

ME



A magnetic contact is required to detect that the door is aligned and then powered (You can check the SERIES CM).

New!

E installation

Embedded installation

The new invisible installation offers architects and engineers a great solution to aesthetic and safety problems. The electromagnet and the counterplate are embedded in the frame and the door leaf respectively. Ideal for swinging or door-only doors.

ME



E

SERIES ME

SLIM AND STRONG

An elegant solution

We have developed the thinnest electromagnetic lock on the market. With only 30mm width it fits on the most sophisticated of your interior decoration without losing holding force.

Not only is the Series ME the smallest, it's also the most sensible to unwanted intruders, being able to detect the smallest tampering attempts.

We like details, for this reason, each unit comes certified with its real closing force and we have accomplished the lowest magnetic remanence.

30 mm

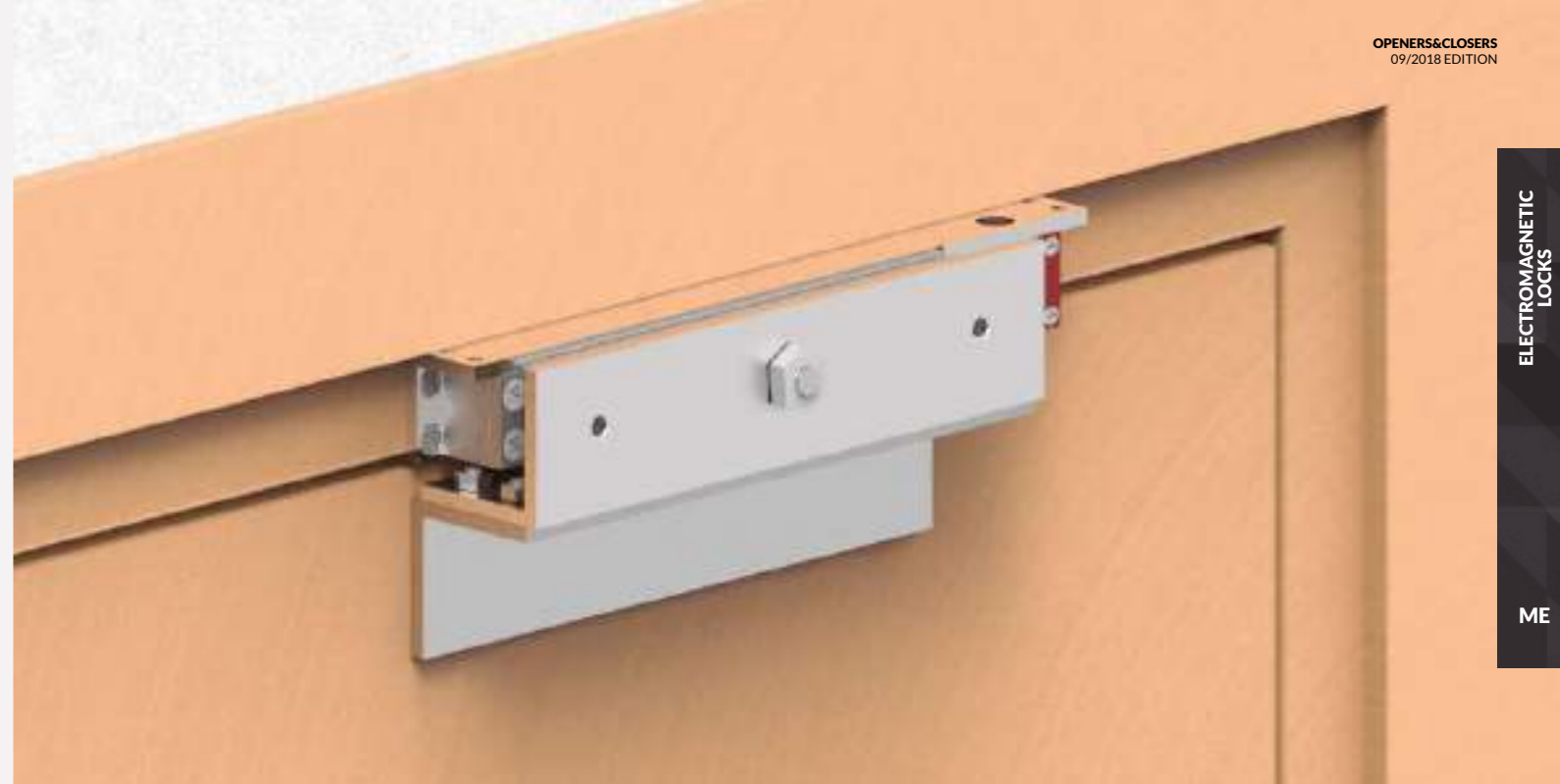

ELECTROMAGNETIC
LOCKS

ME



ME500/510
WATERPROOF IP65
2.500 N Holding force



ME400/420/440
2.800 N Holding force



ME600/620
2.800 N Holding force



ME200/210
2.800 N Holding force
For wood installation

ME201/211
2.800 N Holding force
For metal installation

Counterplate mounting kit
included L and Z installation



ME440: the smart one. The maglock has been fitted with an electric circuit that allows it to activate a timer. Also this electromagnetic lock has an automatic voltage detection system on a broader voltage span (9-24V AC/DC).

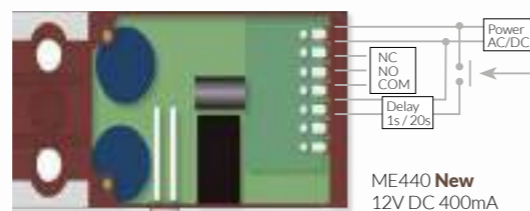

SERIES MEX

MAXIMUM RESISTANCE

High power and low consumption

To satisfy all your needs, we have created a maglock that uses the least amount of power possible without losing any holding force. It comes with an integrated timer, and most models come with a standardized automatic voltage detection system (12-24V AC/DC)

Our vandal protection secures your maglock against external tampering. This ensures that the lock cannot be manipulated, removed or stolen.

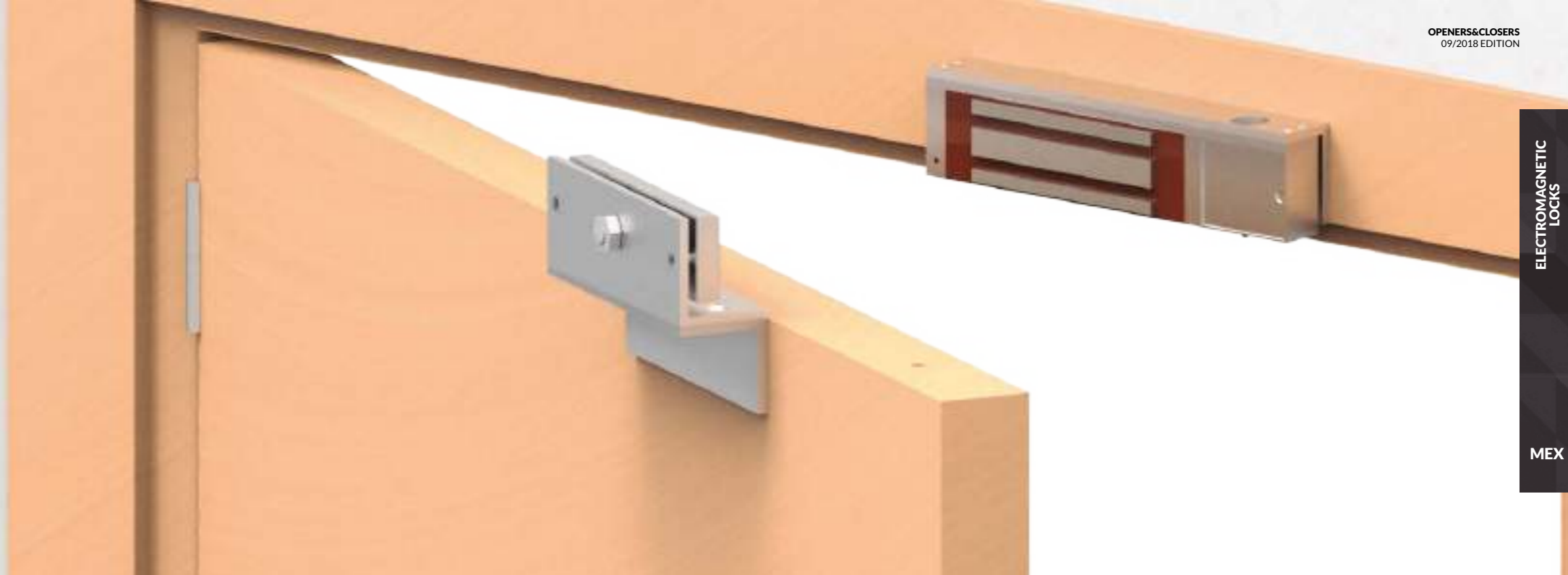

MEX500/530
5.000 N Holding force



MEX400/430
2.800 N Holding force



MEX70
500 N Holding force

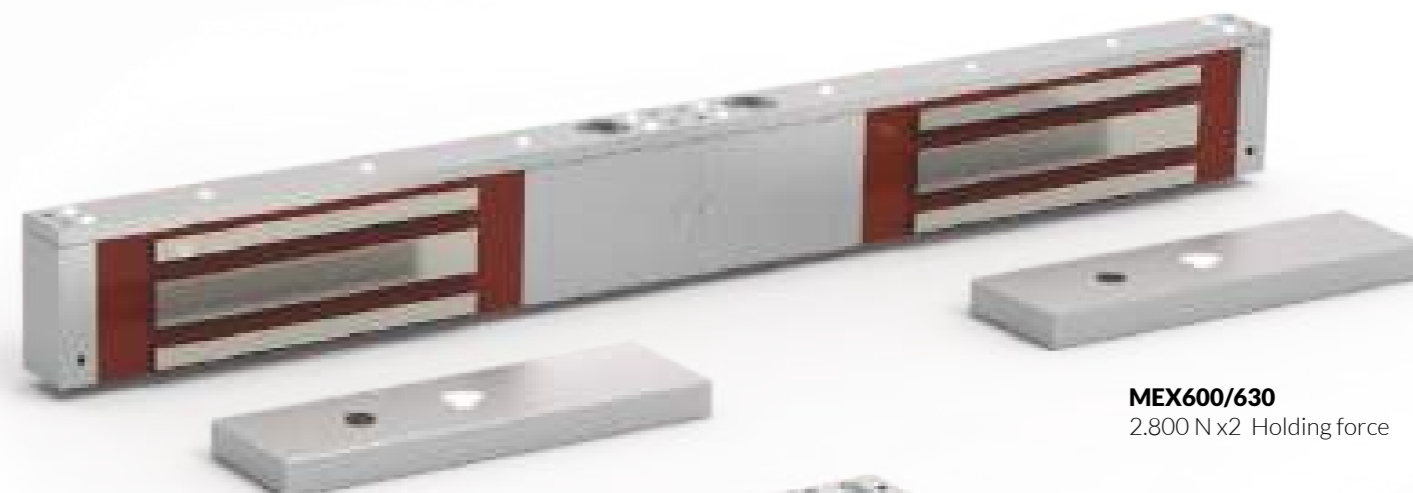





MEX600/630
2.800 N x2 Holding force

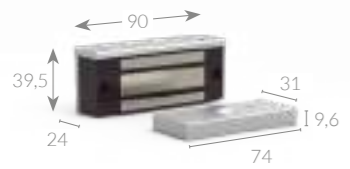

MEX100
1.800 N Holding force

Our smallest and our strongest

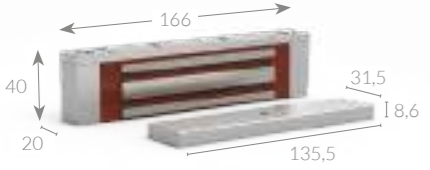
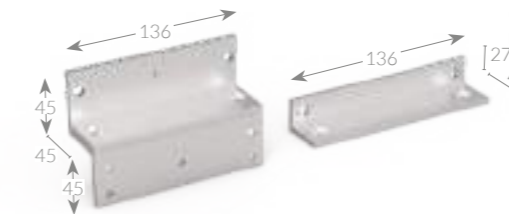
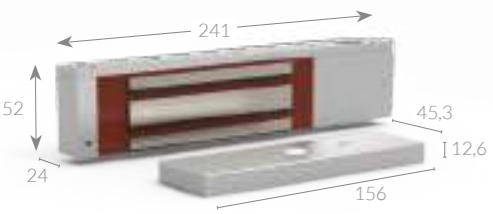
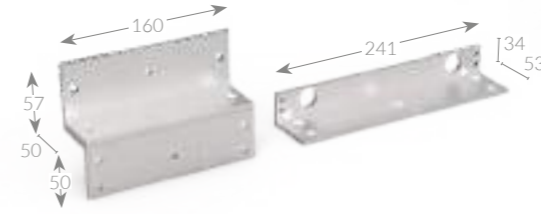
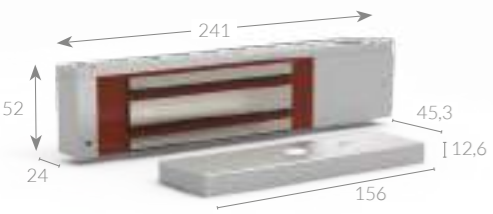
Tiny MEX70 has been specially designed to keep your closets, drawers and showcases properly locked.

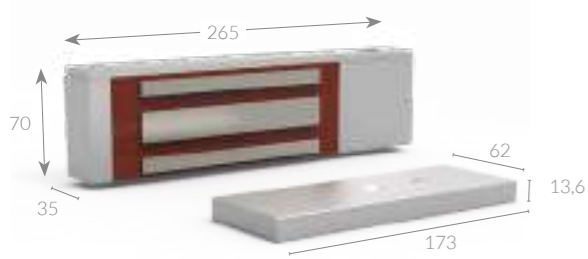
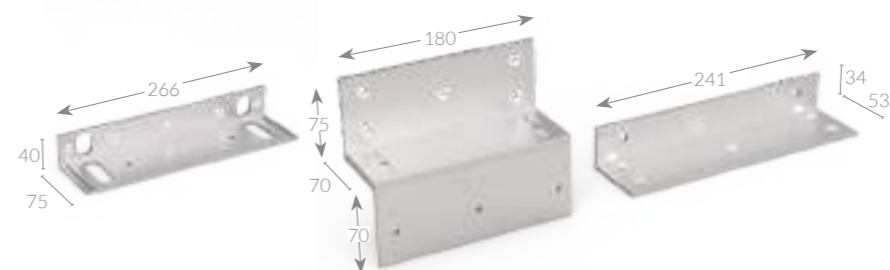
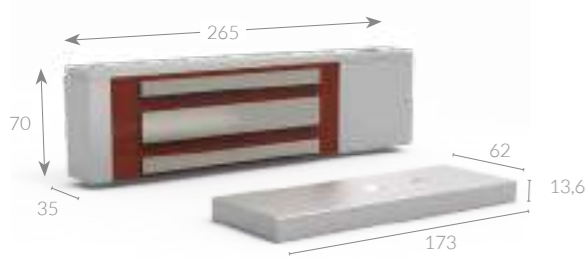
		Holding force	12 V DC	Multivoltage - Manual 12 / 24 VDC	Multivoltage - Automatic 12 - 24 VDC	Door status (Reed)	LED	Timer: 5, 10, 20 o 30 s (5 by default)	L Outward opening doors	Z Inward opening doors	U Glass doors	F Fire Doors	
 <p>3,3 W / 0,5 Kg 12 V DC (300 mA) 24 V DC (150 mA)</p>	MEX70	500 N	-	Yes	-	Yes	-	-					
 <p>3 W / 1,2 Kg 12 V DC (250 mA)</p>	MEX100	1.800 N	Yes	-	-	-	-	-	MEXL1		MEXU2		
 <p>3,3 W / 2,25 Kg 12 V DC (270 mA) 24 V DC (180 mA)</p>	MEX400	2.800 N	-	-	Yes	-	-	-	MEXL2		MEXU3	MF1	
 <p>3,3 W / 2,25 Kg 12 V DC (270 mA) 24 V DC (180 mA)</p>	MEX430	2.800 N	-	-	Yes	Yes	●●	5 s					
 <p>3,3 W / 4,4 Kg 12 V DC (270 mA x2) 24 V DC (180 mA x2)</p>	MEX600	2.800 N x2	-	-	Yes	-	-	-	MEXL2 x2	MEXZ3 x2	MEXU3 x2	MF1 x2	*Remember to order 2 units
 <p>3,3 W / 4,4 Kg 12 V DC (270 mA x2) 24 V DC (180 mA x2)</p>	MEX630	2.800 N x2	-	-	Yes	Yes	●●	5 s					
 <p>3,3 W / 4,1 Kg 12 V DC (270 mA) 24 V DC (180 mA)</p>	MEX500	5.000 N	-	-	Yes	-	-	-	MEXL3			MF1	
 <p>3,3 W / 4,1 Kg 12 V DC (270 mA) 24 V DC (180 mA)</p>	MEX530	5.000 N	-	-	Yes	Yes	●●	5 s					

SERIES DH

DOOR HOLDER

Fire Protection for the most vulnerable

Door holders are used on swinging self-closing doors. These can be found in hospitals, schools, nursing homes as well as other public buildings and are used to automatically isolate an area in case of fire. Since these are very sensitive places, a reliable door holder is key.

These doors are heavy fire-blocking doors that are kept open and closed only during emergencies. To add an extra layer of safety magnetic door holders have a holding force of 600 N and a manual red switch which allows for instant closing of the doors.



Accredited with EN 1155: 1997 certificate

3	5	$\frac{3}{4}$	1	1	3
---	---	---------------	---	---	---

0370-CPR-1178

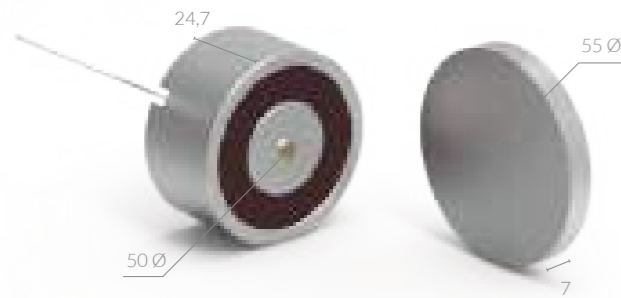

DHI Industrial

Holding force:	600 N
Voltage:	24 V DC
Consumption:	85 mA

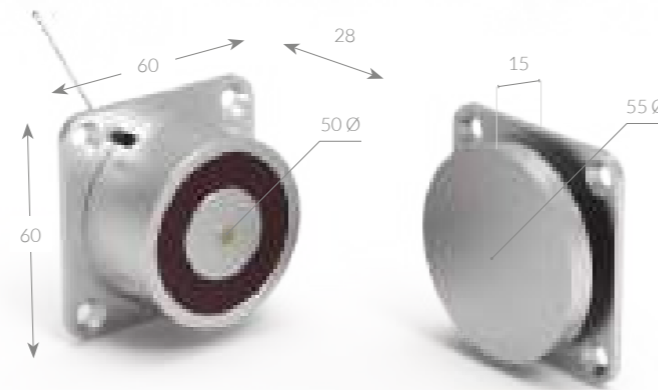

DHS Basic

Holding force:	600 N
Voltage:	24 V DC
Consumption:	85 mA

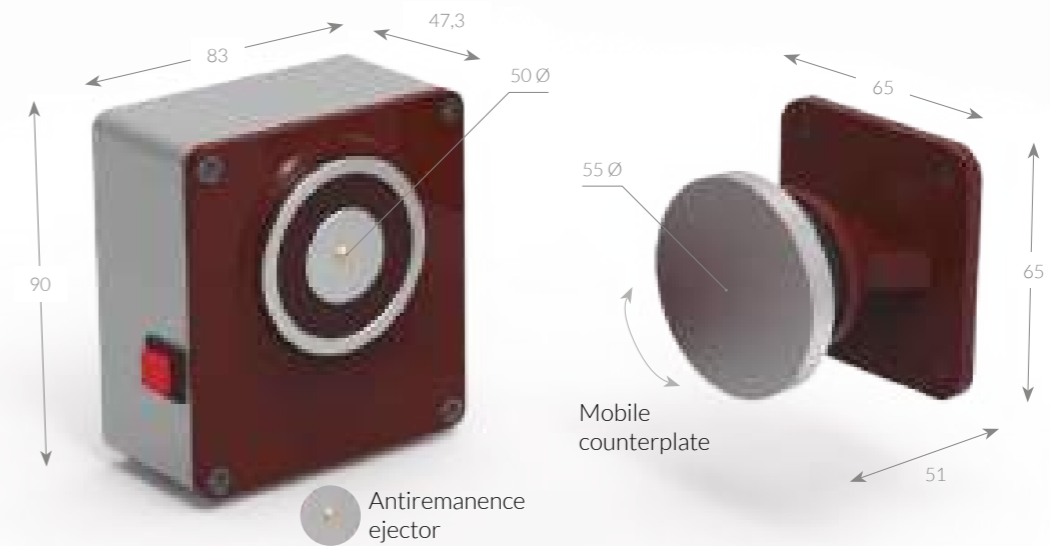

DHT With timer

Holding force:	600 N
Voltage:	24 V DC
Consumption:	85 mA
Timer:	3 s

DHB Dual voltage

Holding force:	600 N
Voltage:	12 V DC 24 V DC
Consumption:	170 mA 85 mA
With jumper for	Dual voltage

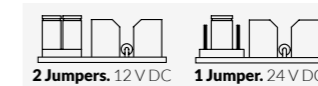

DHD With power-regulation

Holding force:	300 N 600 N
Voltage:	24 V DC
Consumption:	85 mA

Accessories & Spares



AHI counterplate for DHI



AHS counterplate for DHS



PDH manual release button

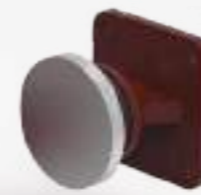

ADH for DHB DHT DHD



Floor - DF1 - Wall



FIX SUPPORT



Floor - DF2 - Wall

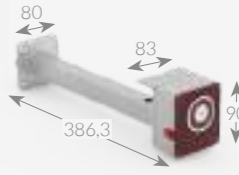

SERIES SH SHEARLOCK

Sleek and mighty

In this day and age where minimalism is so in vogue, it is pretty usual to have glass swinging and sliding doors even in the most sensitive of work environments.

Shearlocks are excellent for this kind of doors because they combine magnetic and mechanical forces to create a holding force five times higher than your average maglock, reaching up to 15.000N! This makes the Series SH a perfect candidate to work as a sort of independent access control system, all on its own.

Shearlocks can be easily hooked to heat and smoke detectors as well as various access control systems and keypads. We have also included a timer for both locking and unlocking which is ideal for clearance through keypads or electronic readers that are not situated next to your shearlock protected door.

Most electromagnetic locks come with two LEDs that inform whether the door is closed or open. For your convenience, we have added a third LED to report malfunction. This way you will be able to detect when your shearlock is not properly engaged at a glance.

SIGNAL
lights

ELECTRO
magnetic

Technical features

Holding force:	15.000 N
Power from	10 to 36 V DC (automatic switch)
Consumption at 12 V DC:	2A (start up) and 0,5A (operating)
Timer:	Adjustable from 0 to 25 seconds for both locking (T1) and unlocking (T2)
Operating temperature:	from -14 to +40 °C
Auxiliary relay:	1A a 24 V DC maximum

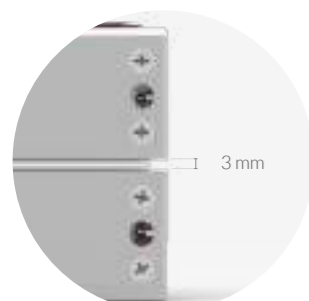
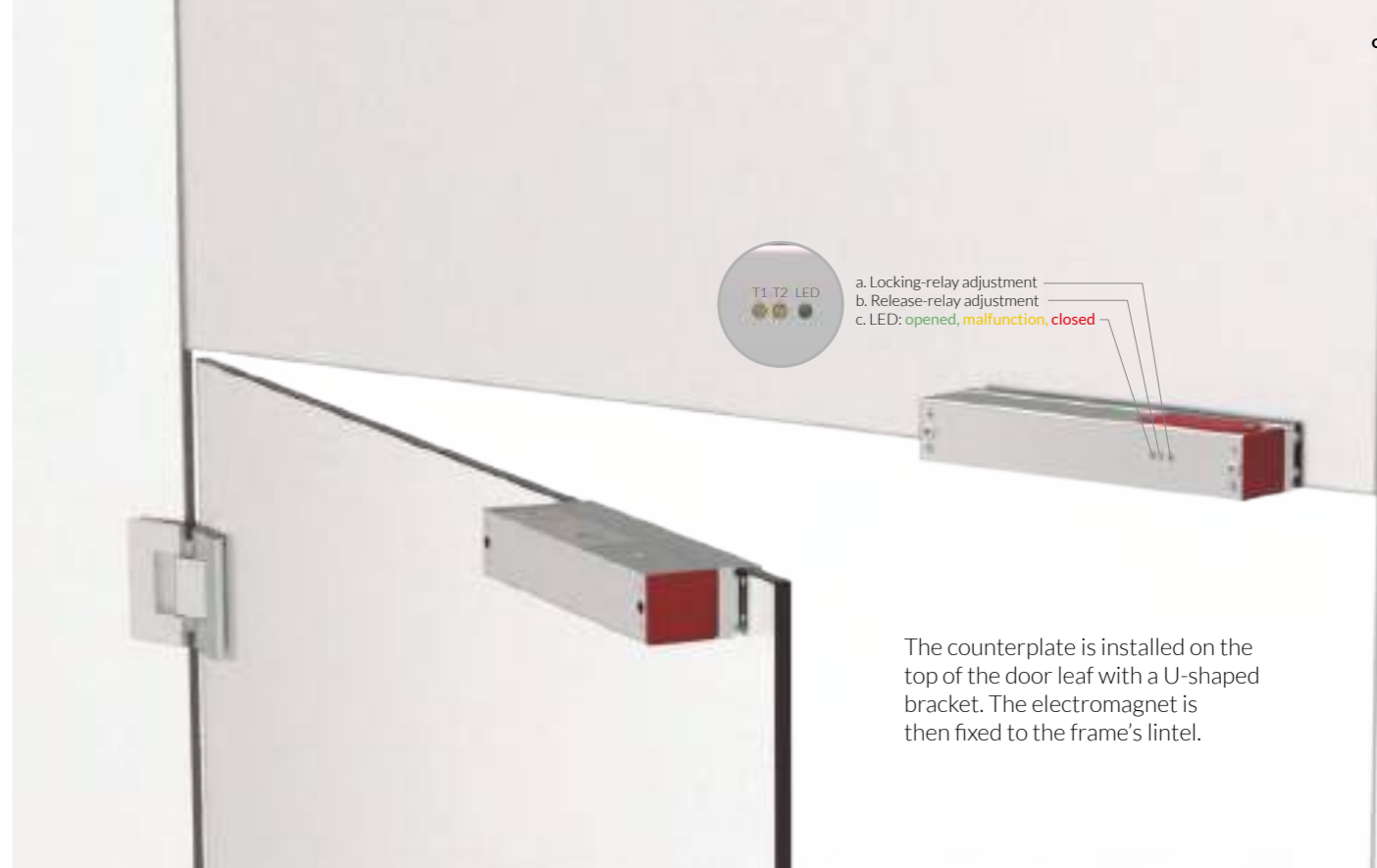

3 mm
Maximum distance
between parts



6,5 a 14 mm
Minimum distance between
glass: 6.5 mm
Maximum thickness of the glass: 14 mm



SH100
Surface
installation

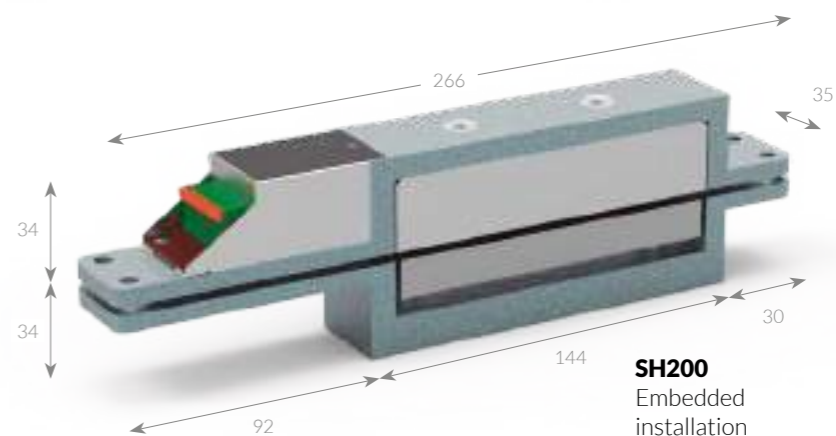

SH200
Embedded
installation



SH300
Glass / glass installation

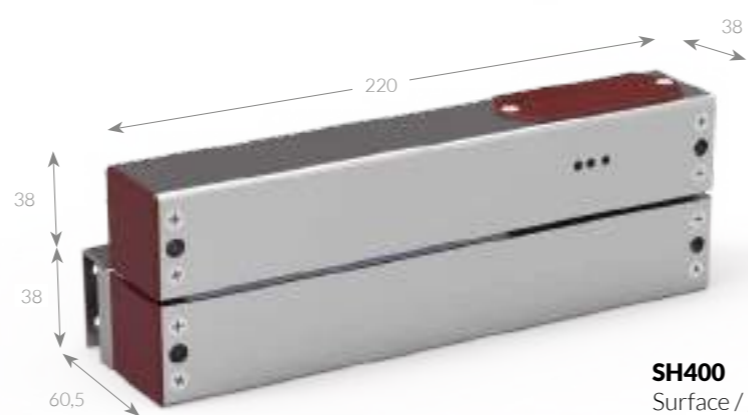

SH400
Surface / glass installation

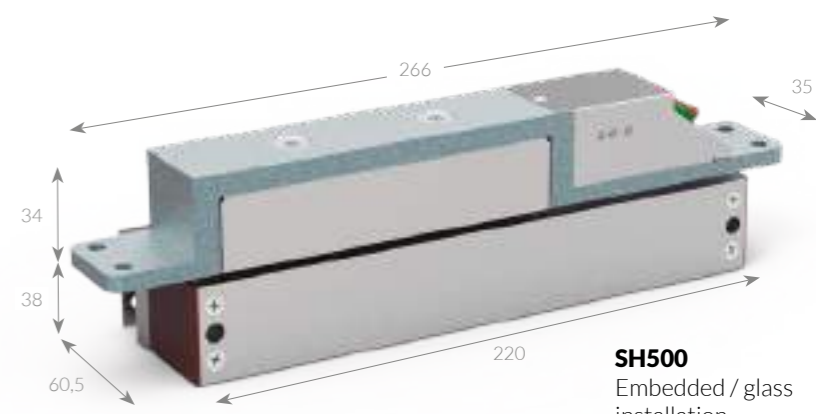

SH500
Embedded / glass
installation

ELECTRIC LOCKS

The electric lock is a locking device which is operated by an electrical current and is usually connected to an access control system. It is unlocked through a physical object (key, card, fingerprint, etc.), secret code (key or password) or a combination of both. This allows for greater security of access and control of your activity.

SERIES PGX

MICRO BOLT

Small and infallible

The best way of ensuring the safety of all manner of bins, lockers, showcases and more. It can be operated from the front or the side, giving it great versatility and making it an unbeatable option for small spaces.



ELECTRIC
LOCKS

PGX

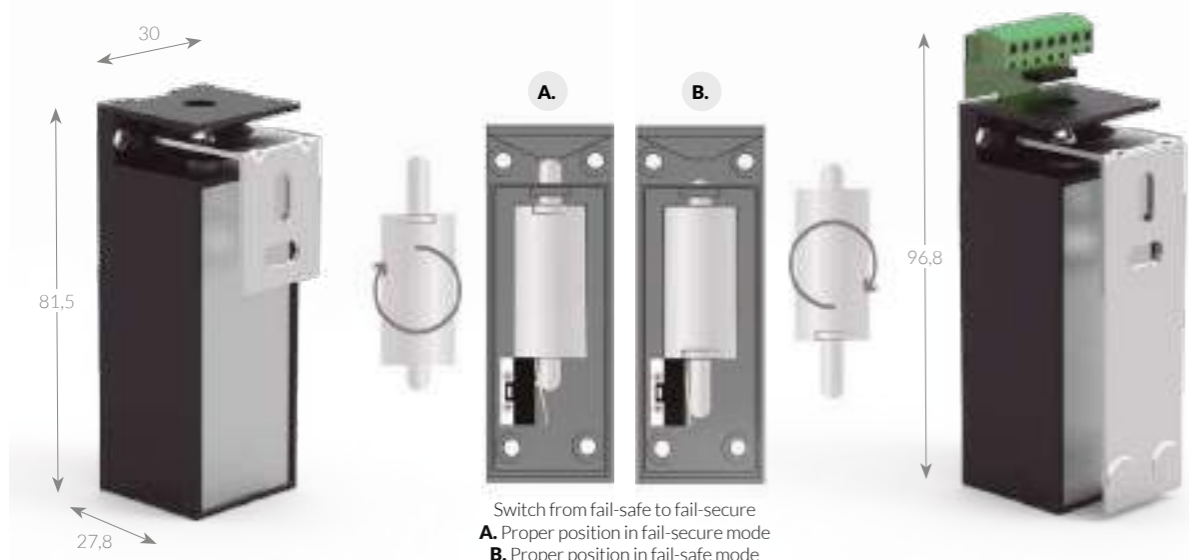

Switch from fail-safe to fail-secure
A. Proper position in fail-secure mode
B. Proper position in fail-safe mode

PGX01	
Voltage:	12 / 24 V DC
DC Consumption:	300 mA / 150 mA
DC power:	3,6 W
Rated resistance:	40 Ohms

PGX02	
Voltage:	12 / 24 V DC
DC Consumption:	300 mA / 150 mA
DC power:	3,6 W
Rated resistance:	40 Ohms

With monitoring:

1. Lock status. Micro-switch	
Rating:	1A / 30 V DC
2. Door status. Reed switch:	Max 10W
(Max Switching Contact:	0,5 A)

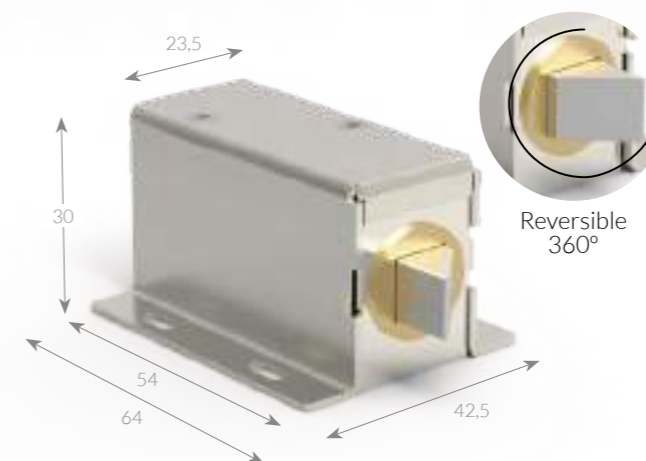

PGX03	
Voltage:	12 V DC
DC current consumption:	700 mA
DC power:	7,8 W
Rated resistance:	18,46 Ohms
Timer:	1s energized < 10s
Latch length:	10 mm

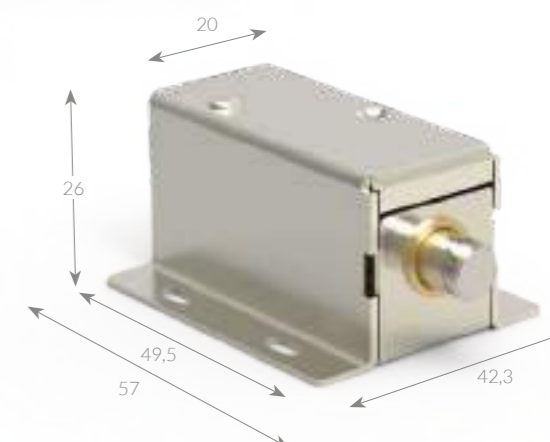

PGX04	
Voltage:	12 V DC
DC current consumption:	350 mA
DC power:	4,2 W
Rated resistance:	37 Ohms
Timer:	1s energized < 10s
Latch length:	6 mm

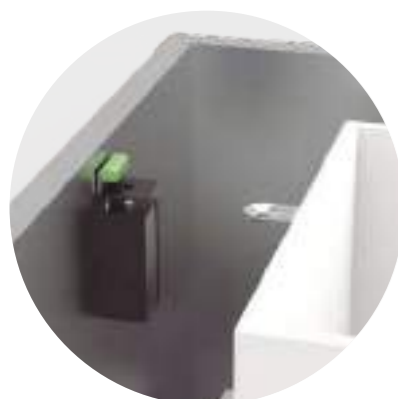

Sliding drawer



Sliding door



Pull door



Swinging doors



Swinging doors

SERIES CE

INTELLIGENT ELECTRIC LOCK

We overcome any obstacle

Our electric locks are 100% reversible. They have a side-sliding cylinder from 50 to 70 mm and an adjustable front. They are usually installed on both wooden and metal interior doors, gates and hinged parking doors. For improved security, they can be unlocked using an access control system or a key (3 keys included).



MOTORIZED Technical characteristics

Voltage:	12-24 V DC
Consumption:	340 mA - 170 mA
Installation:	Surface
Material:	Nickel

**ACOUSTIC
Alarm**
When the door does
not close properly

**Magnetic
SENSOR**

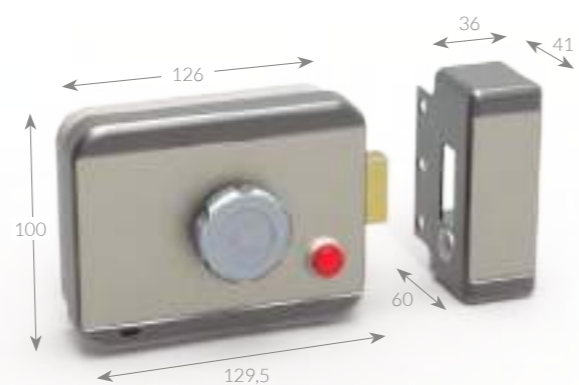

CE104
With push button
(Temporary unlocking)

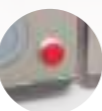

CE105
With switch
(permanent release)



CE106
With knob



CE109
With key (cylinder)



VCX100 (Optional)
Steel visor to cover the lock.
Outdoor rain cover

ELECTRIC Technical characteristics

Voltage:	8 - 12 V AC/DC
Consumption:	1,5 A starting 0,9A (8 V AC), 1,7A (12 V AC), 2,4A (8 V DC), 3,6A (12 V DC)
Installation:	Surface
Material:	Steel case
Adjustable input distance:	50 - 70 mm



CE110
With key



CE111
With mechanical pushbutton



CE112
With key and mechanical pushbutton



VCX200 (Optional)
Steel visor to cover the lock.
Outdoor rain cover

SERIES OC

BASIC

Simple and Effective

The minimalist design of the electric bolt lock with a strong steel housing makes it an elegant and easy to install series. In addition, the range of models now includes the variant for glass doors in both vertical and horizontal formats. A good choice for simple and economical solutions.

Technical characteristics

Voltage:	12 V DC
Start-up consumption:	800 mA
Operating consumption:	130 mA
Programmable opening timer:	0, 3, 6, 9 s
Door status (open or closed):	Yes (Signal exportable)
Bolt status (inside or outside):	Yes (Signal not exportable)
Installation:	Embedded, Surface and Glass installations



OC860
FAIL-SECURE
Embedded Installation

OC870
FAIL-SAFE
Embedded Installation

OC880
FAIL-SAFE
Surface Installation

OC890
FAIL-SAFE
Glass Installation

SERIES BO

BASIC AND VERSATILE

The improved electronics of the electric bolt lock allows for multiple options when integrating with other systems. It provides further information on the status of the door and bolt, as well as about the attempts to unlock it. All signals can be exported for analysis.

These bolt locks have been designed to provide greater flexibility in building management, as well as more real and up-to-date control of each unit.

This electronic bolt lock allows it to operate as an interlocking door system. The interlocking doors operate in such a way that when the two doors are closed, either one of them can be opened; and when one of them is opened, the other remains closed.

Technical characteristics

Voltage:	12 or 24 V DC
Start-up consumption:	1.150 / 210 mA
Operating consumption:	800 / 90 mA
Programmable opening timer:	0, 2.5, 5, 8 s
Door status (open or closed):	Yes (exportable signal)
Bolt status (open or closed):	Yes (exportable signal)
Installation:	Embedded

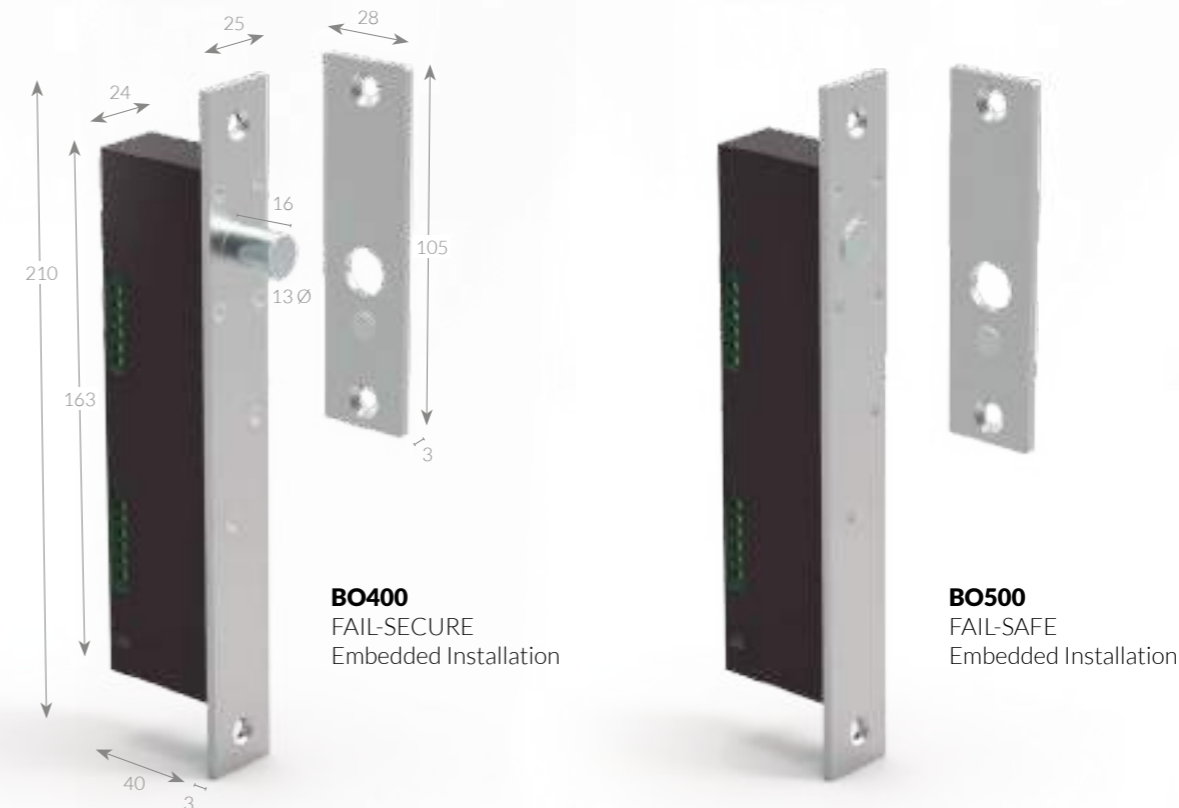

BO400
FAIL-SECURE
Embedded Installation

BO500
FAIL-SAFE
Embedded Installation

SERIES EVA

DUAL FUNCTIONALITY

No wiring

The EVA series consists of:

A mechanical part (installed on the door leaf)

An electrical part (installed on the door frame) This system's strength lies in a mechanical part that does not require electrical wiring for installation. The bolt is ejected automatically when the door is closed and can be opened using an electric impulse, handle or key. The simplicity of this lock offers a good solution for installations that require extra security.



Suitable for
EUROPEAN
camera profiles

Suitable
for **SALINE**
environments

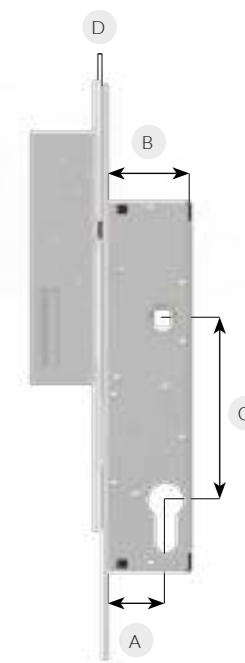

Technical characteristics

Voltage:	12V-15W (AC-DC)
Consumption:	900 mA
Door status:	Yes (Optional)
Bolt status:	Yes (Optional)
Complies with the directive:	EN179

3 6 5 0 1 3 2 1 A B/D

0099-CPR-A44-0156

OPTIONALS	Door status (Reed)	Hinged door function	Rounded Faceplate	A	B	C	D
				EVA20	R	B	FR
EVA25	R	B	FR	25	38,5		
EVA30	R	B	FR	30	43,5		
EVA35	R	B	FR	35	48,5		
EVA40	R	B	FR	40	53,5		
EVA50	R	B	FR	50	60,5		
EVA60	R	B	FR	60	70,5		

OPTIONALS



ACCESSORIES

O&C carries a whole line of accessories to complete your access control system installation such as indicator lights, electric contacts, power supplies and door loops.

SERIES PB

DETECTION SYSTEM AND FIRE ALARMS

One touch in security

- Semi-recessed
- Without screws
- Slim-fit



PB1 - One contact
PB2 - Two contacts



PB3
PB3M



PB4



PB5

Transparent cover (Optional)



High brightness LED of 3 mm

Key to reset and open the box

Evacuation systems

Evacuation button

The manual evacuation push buttons are activated to allow the aperture of the access control systems in case of generalized failure.

They are resettable with a key and have an extractable terminal strip to an easier installation.

Fire detection systems

Alarm button

In case of fire, the manual alarm push button can be activated to inform the emergency fire panel.

The precise identification of the fire location will depend to which fire alarm detection system is connected. It could be conventional, addressable or analog addressable.

Automatic gaseous fire suppression system

The manual push button for automatic gaseous fire suppression systems are designed to activate or block/abort manually the extinction of clean, inert and CO2 agents.

Stop button

This locking button prevails over the extinguishing trigger button. The function is to block or abort the automatic gaseous fire suppression system.

Trigger button

When is activated the trigger button, the control panel is informed to activate the extinction process. Following the European normative this process will take maximum 60 seconds.

Technical characteristics	PB1 & PB2 Evacuation	PB3 & PB3M Fire and memory
Voltage:	-	24 V DC (Operating voltage)
Output signal:	Contact NA - C - NC	-
Consumption:	35 mA 77 mA	35 mA 77 mA
Certificate:	Norm EN 54-11	Norm EN 54-11
Option:	Reactivatable	Reactivatable
Material:	ABS Green color	ABS Red color

0099-CPR-A74-0075

PB4 Stop	PB5 Trigger
-	-
Contact C, NC, NA	Contact C, NC, NA
35 mA 77 mA	35 mA 77 mA
Norm EN 54-11 (EN-12094-3)	Norm EN 54-11 (EN-12094-3)
Reactivatable	Reactivatable
ABS Blue color	ABS Yellow color

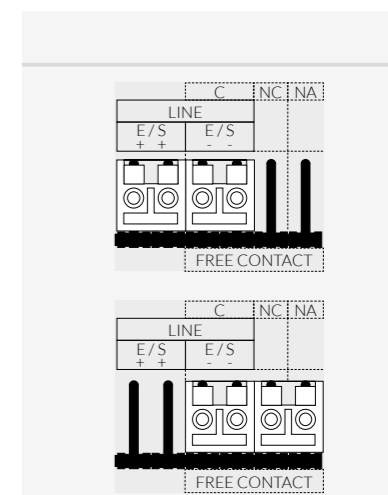

SERIES TL

INDICATOR LIGHTS

Policing your access in style

For a correct visual and/or acoustic management of the installations, the luminous indicators combine design, robustness and functionality.

The curvature of the green and red indicator, allows to expand the beam of light in a homogeneous way and to be visualized from all angles. Depending on the position of the jumper, the status of the indicator will remain permanent or intermittent.

Operates from 10 to 24V AC/DC.



ACCESSORIES

TL



All models can be installed Embedded **E** or Surface mounted **S**

TL1

TL2
With push button (NO)

TL3
With acoustic warning

TL4
With push button and acoustic warning



WITH JUMPER

The audible warning device and the LED light remains in steady mode.

WITHOUT JUMPER

The audible warning device and the LED light remains in flashing mode.

SERIES PS

POWER SUPPLIES

Providing energy to your strikes

It is used to convert the voltage from alternating current (usually 220V AC) into a lower, direct current (12 or 24V DC).

These power supplies can be connected to batteries and can be supplied with a small metallic closet, a battery charger, 4 posts to connect a maximum of 2 electromagnetic locks each, an individual switch and luminous signalization.



PSBOX

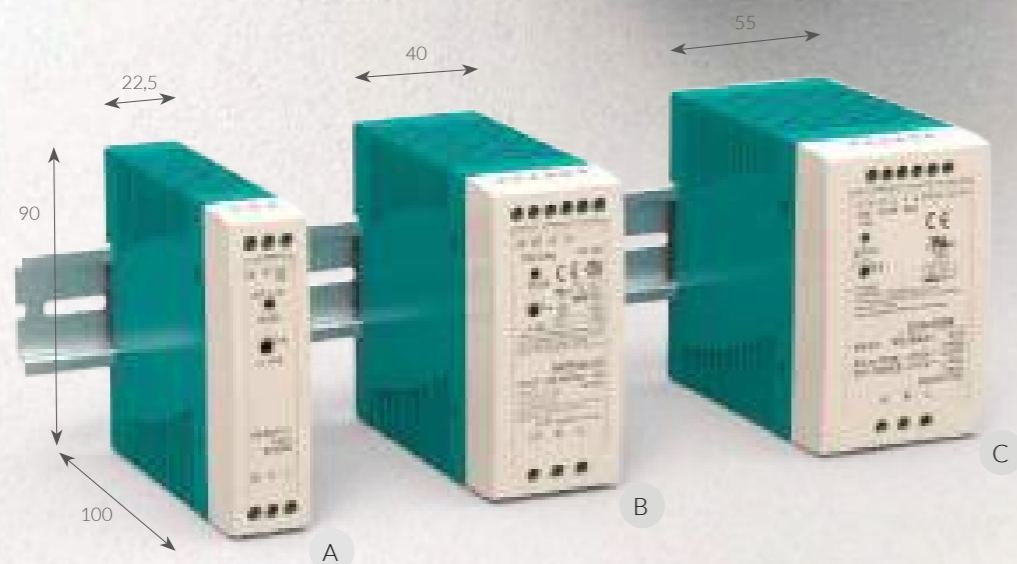

A	Power	Voltage	B	Power	Voltage	C	Power	Voltage
PS1012	10 W	12 V	PS4012 (B)	40 W	12 V	PS10012 (B)	100 W	12 V
PS1024	10 W	24 V	PS4024 (B)	40 W	24 V	PS10024 (B)	100 W	24 V
PS2012	20 W	12 V	PS6012 (B)	60 W	12 V			
PS2024	20 W	24 V	PS6024 (B)	60 W	24 V			

Letter (B) Item Reference

If the option (B) appears in the references, it means that his model has an auxiliary battery connector (battery is not included).

TRANSFORMERS

Changing the world one volt at a time

Transformers convert the high voltage from the power outlet - which is usually around 220V AC - to the lower voltage needed for the electric strike (12-24V AC).

Our transformers have 4 terminals and come equipped with monitoring light LED, battery charger and backup. They are prepared for an installation on a DIN rail.

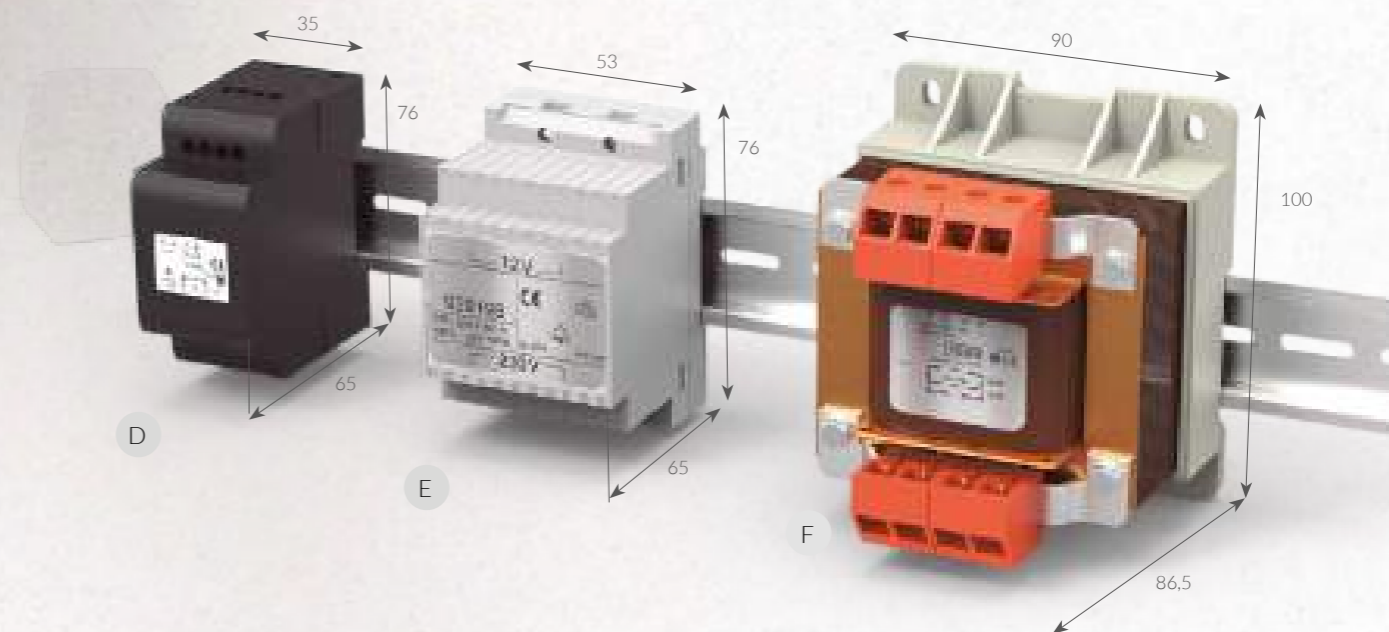

	D PS1210T	E PS1219T	F PS1263T
Voltage:	230/12 V	230/12 V	230/12-24 V
Power:	10 VA	19 VA	63 VA
Weight:	0,335 Kg	0,473 Kg	1,5 Kg

SERIES DDC

ELECTRIC CONTACTS

Getting rid of cables

O&C high-quality electric contacts are designed to provide your locks with electricity discretely and efficiently without any visible wiring. The small contacts go embedded into door and door frame on the side of the hinges. This way the contacts remain completely invisible once the door closes.

The DDC1 electric contact has been designed for intermittent service. Two brass poles are plated in nickel, and the plastic parts can be either black or white.

For permanent connection and sliding doors, we recommend the series DDC2, DDC3 and DDC4. These electric contacts have silver plated brass poles mounted in white or black plastic housing.

Technical characteristics:	DDC1	DDC2 DDC3 DDC4
Voltage:	24 V	24 V AC/DC
Consumption:	1,5 A	0,5 A
Continuous operation:	Max. 10 / 40 seg	100% ED

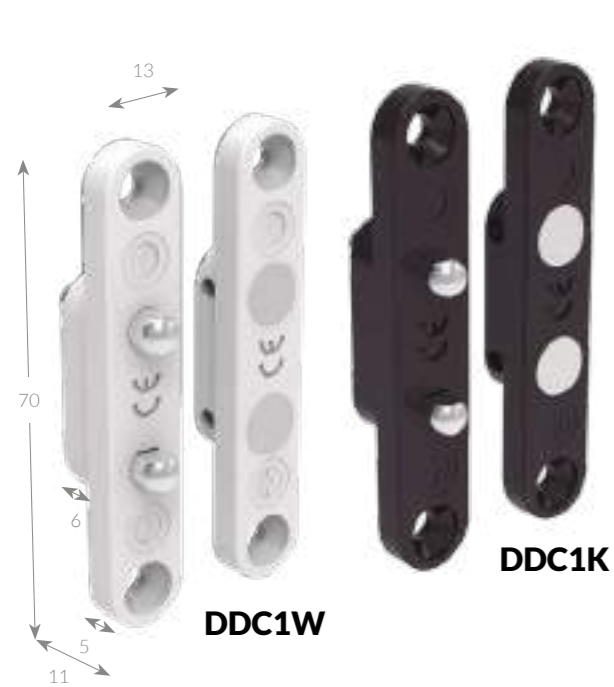

SERIES FX DOOR LOOPS

Keeping your security invisible

The door loops are a safe method for transfer the power from the door frame to the electric lock located on the door leaf. We protect and hide the cables inside a flex tube so that the operation of the electric locks or other accessories are not compromised to unwanted manipulations.

The internal diameter of 10 mm is large enough to house the most common cables used in the control of the doors. They will always maintain a constant current supply and without interference with the opening of the door.

E Embedded



RTFX
Opcional

	FX290	FX510
Finish color:	Nickel	Nickel
Internal diameter:	10.5 mm	10.5 mm
Flex tube length:	150 mm	370 mm
Total length:	290 mm	510 mm

S Surface



	FX150	FX230	FXT230	FX370	FX500	FX300G FX300B	FX500G FX500B
Finish color:	Nickel	Nickel	Nickel	Nickel	Nickel	Grey or Brass	Grey or Brass
Internal diameter:	10.5 mm	10.5 mm	8 mm	10.5 mm	10.5 mm	10 mm	10 mm
Flex tube length:	150 mm	230 mm	230 mm	370 mm	500 mm	300 mm	500 mm
Total length:	250 mm	330 mm	330 mm	470 mm	600 mm	440 mm	640 mm

SERIES CM

MAGNETIC CONTACTS

Keeping an eye on your doors and windows

These are reed switches made out of two ferrous contacts. When approached by a magnetic field they close the circuit. Used to detect the status of the doors and windows, magnetic contacts are generally attached to access control systems like fire alarms and indicator lights.



The installation is straightforward: the reed switch is connected to the door or window frame and the magnet to the leaf.

Reed contact characteristics

Max Voltage: 200 V DC
Max. Current: 500 mA
Max. Power 10 VA
Initial resistance to contact R = 0,1 Ω
Isolation Resistance: R= 10 ¹² Ω
Temperature -40°C / 125°C
Mean time between failures (MTBF): 10 ⁸

E
Embedded



CMI002



CMI016



CMI122
Operating distance: 20 mm
10 mm (on iron surfaces)



CMI130
Operating distance: 20 mm
10 mm (on iron surfaces)

S
Surface



CME045
Temperature: -10°C / 40°C



CMC005



CMB003



CMB020

	Material	Distance	Reed	Magnet	Grade 2	* Grade 3
E	CMI002	Brass	12 mm	29,5 x 7,5 Ø	27,5 x 7,5 Ø	
	CMI016 *	ABS	15 mm	29,5 x 7,5 Ø	29 x 7,5 Ø	
	CMI122 *	ABS	20 / 10 mm	29 x 20 Ø	29 x 20 Ø	
	CMI130	Brass	20 / 10 mm	18 x 20 Ø	18 x 20 Ø	
	CME045 *	Plastic (colors)	25 - 40 mm	56 x 16 x 5	56 x 16 x 5	
S	CMC005 *	Aluminium	25 / 18 mm	58 x 15 x 20	58 x 15 x 20	
	CMB003	Plastic with glass	25 / 18 mm	85 x 38 x 13	50 x 26 x 25	
	CMB020	Aluminium	35 / 30 mm	130 x 42 x 15	98 x 30 x 25	
					Complies with EN50131 - 2 - 6 Grade 2 Class 4	Complies with Grade 3 on request:
					With 4 cables	CMI016 CMI122 CME045 CMC005

SERIES AC

ACTIVATING DOORS REMOTELY

Keyboards and Remote Controls

Keyboards and remote controls offer convenience and security at access points.

Our encrypted keypad offers a high degree of anti-vandalism security. The steel case is designed to withstand heavy impacts, and the beautiful stainless steel buttons ensure a longer useful life.

Additionally, the keypad is IP45 certified which means liquid protection. Besides a time delay of 1 to 99 seconds, each relay allows the configuration of 12 codes for each circuit, with a total of 24 codes for the 2 independent circuits:

- Monostable Circuit: Activates the lock during a determined time.
- Flip-flop Circuit: Activates the lock until the code is re-entered.

In the absence of power, all information remains stored.

Our remote control consists of a transmitter and a receiver that send/receive the opening/closing signal in coded form. The settings are easily made via the transmitter and are very useful for easy access in stores when there is an input display.

It is possible to use up to 15 remote controls (ACM) with one receiver (ACR).



IP45

24 codes

Built-in memory

Timer from 1 to 99 s

Technical characteristics

Power supply:	12V AC/DC + 10%
Consumption	2A (start-up) and 0,02A (operating)
Maximum relay current:	2A
Number of codes for Relay 1:	12 + direct activation
Number of codes for Relay 2:	12 + direct activation
Timer:	from 1 to 99 seconds (or flip-flop)
Operating temperature:	from 0° to +40°C
Maximum humidity:	85% RH
Protection grade:	IP45



AC100
Coded keypad



ACR
Receiver

ACM
Remote control

Technical characteristics

Voltage:	12V DC
Operating current:	0,02A
Storage capacity:	15PCS
Output signal:	NO / NC / COM
Connection diagram:	DJ02 series
Adjustment button:	Yes



OPENERS & CLOSERS S.L. Reserves the right to make changes at any time without notice. Images may show optional accessories and specific country variants may differ. Colors, quoted technical and electric characteristics may vary. Additional information may be obtained directly from OPENERS & CLOSERS Central Offices located in Barcelona, Spain.